



An Oshkosh Corporation Company

Operation and Safety Manual

Original Instructions - Keep this manual with the machine at all times.

Model

3369LE/4069LE

M3369/M4069



P/N - 3121220

December 10, 2010

FOREWORD

This manual is a very important tool! Keep it with the machine at all times.

The purpose of this manual is to provide owners, users, operators, lessors, and lessees with the precautions and operating procedures essential for the safe and proper machine operation for its intended purpose.

Due to continuous product improvements, JLG Industries, Inc. reserves the right to make specification changes without prior notification. Contact JLG Industries, Inc. for updated information.

SAFETY ALERT SYMBOLS AND SAFETY SIGNAL WORDS



This is the Safety Alert Symbol. It is used to alert you to the potential personal injury hazards. Obey all safety messages that follow this symbol to avoid possible injury or death

DANGER

INDICATES AN IMMINENTLY HAZARDOUS SITUATION. IF NOT AVOIDED, WILL RESULT IN SERIOUS INJURY OR DEATH. THIS DECAL WILL HAVE A RED BACKGROUND.

WARNING

INDICATES A POTENTIALITY HAZARDOUS SITUATION. IF NOT AVOIDED, COULD RESULT IN SERIOUS INJURY OR DEATH. THIS DECAL WILL HAVE AN ORANGE BACKGROUND.

CAUTION

INDICATES A POTENTIALITY HAZARDOUS SITUATION. IF NOT AVOIDED, MAY RESULT IN MINOR OR MODERATE INJURY. IT MAY ALSO ALERT AGAINST UNSAFE PRACTICES. THIS DECAL WILL HAVE A YELLOW BACKGROUND.

NOTICE

INDICATES INFORMATION OR A COMPANY POLICY THAT RELATES DIRECTLY OR INDIRECTLY TO THE SAFETY OF PERSONNEL OR PROTECTION OF PROPERTY.

⚠ WARNING

THIS PRODUCT MUST COMPLY WITH ALL SAFETY RELATED BULLETINS. CONTACT JLG INDUSTRIES, INC. OR THE LOCAL AUTHORIZED JLG REPRESENTATIVE FOR INFORMATION REGARDING SAFETY-RELATED BULLETINS WHICH MAY HAVE BEEN ISSUED FOR THIS PRODUCT.

NOTICE

JLG INDUSTRIES, INC. SENDS SAFETY RELATED BULLETINS TO THE OWNER OF RECORD OF THIS MACHINE. CONTACT JLG INDUSTRIES, INC. TO ENSURE THAT THE CURRENT OWNER RECORDS ARE UPDATED AND ACCURATE.

NOTICE

JLG INDUSTRIES, INC. MUST BE NOTIFIED IMMEDIATELY IN ALL INSTANCES WHERE JLG PRODUCTS HAVE BEEN INVOLVED IN AN ACCIDENT INVOLVING BODILY INJURY OR DEATH OF PERSONNEL OR WHEN SUBSTANTIAL DAMAGE HAS OCCURRED TO PERSONAL PROPERTY OR THE JLG PRODUCT.

For:

- Accident Reporting
- Product Safety Publications
- Current Owner Updates
- Questions Regarding Product Safety
- Standards and Regulations Compliance Information
- Questions Regarding Special Product Applications
- Questions Regarding Product Modifications

Contact:

Product Safety and Reliability Department
JLG Industries, Inc.
13224 Fountainhead Plaza
Hagerstown, MD 21742

or Your Local JLG Office
(See addresses on manual rear cover)

In USA:

Toll Free: 877-JLG-SAFE (877-554-7233)

Outside USA:

Phone: 240-420-2661
E-mail: ProductSafety@JLG.com

REVISION LOG

Original Issue	- May 5, 2005
Revised	- May 24, 2005
Revised	- August 11, 2006
Revised	- March 29, 2007
Revised	- May 21, 2008
Revised	- December 10, 2010

SECTION - PARAGRAPH, SUBJECT	PAGE
SECTION - 1 - SAFETY PRECAUTIONS	
1.1 GENERAL	1-1
1.2 PRE-OPERATION	1-1
Operator Training and Knowledge	1-1
Workplace Inspection	1-2
Machine Inspection	1-3
1.3 OPERATION	1-3
General	1-3
Trip and Fall Hazards	1-4
Electrocution Hazards	1-5
Tipping Hazards	1-7
Crushing and Collision Hazards	1-8
1.4 TOWING, LIFTING, AND HAULING	1-9
1.5 MAINTENANCE	1-9
General	1-9
Maintenance Hazards	1-10
Battery Hazards	1-10
SECTION - 2 - USER RESPONSIBILITIES, MACHINE PREPARATION AND INSPECTION	
2.1 PERSONNEL TRAINING	2-1
Operator Training	2-1
Training Supervision	2-1
Operator Responsibility	2-1

SECTION - PARAGRAPH, SUBJECT	PAGE
2.2 PREPARATION, INSPECTION, AND MAINTENANCE	2-2
2.3 PRE-START INSPECTION	2-4
Preparing the Machine for Operation	2-5
Function Check	2-5
2.4 OSCILLATING AXLE LOCKOUT TEST (IF EQUIPPED)	2-7
GENERAL	2-9
Limit Switch Locations	2-11
SECTION - 3 - MACHINE CONTROLS AND INDICATORS	
3.1 GENERAL	3-1
3.2 CONTROLS AND INDICATORS	3-1
Ground Control Station	3-1
Platform Control Station	3-3
SECTION - 4 - MACHINE OPERATION	
4.1 DESCRIPTION	4-1
4.2 POWER SELECT	4-1
Platform/Ground Select	4-1
4.3 RAISING AND LOWERING	4-1
Raising & Lowering	4-1
4.4 LEVELING JACKS	4-2
4.5 PLATFORM EXTENSION	4-2

TABLE OF CONTENTS

SECTION - PARAGRAPH, SUBJECT	PAGE
4.6 PLATFORM HANDRAILS FOLD DOWN PROCEDURE (IF EQUIPPED)	4-2
4.7 STEERING	4-2
Traveling Forward and Reverse	4-4
4.8 SHUT DOWN AND PARK	4-4
4.9 SAFETY PROP	4-5
4.10 BATTERY CHARGING PROCEDURE	4-5
4.11 TIE DOWN/LIFTING	4-5
Tie Down	4-5
Lifting	4-5

SECTION - 5 - EMERGENCY PROCEDURES

5.1 GENERAL	5-1
5.2 INCIDENT NOTIFICATION	5-1
5.3 EMERGENCY TOWING PROCEDURES	5-1
5.4 MANUAL DESCENT SYSTEM	5-2
5.5 EMERGENCY OPERATION	5-2
Operator Unable to Control Machine	5-2
Platform Caught Overhead	5-2

SECTION - PARAGRAPH, SUBJECT	PAGE
SECTION - 6 - GENERAL SPECIFICATIONS AND OPERATOR MAINTENANCE	

6.1 INTRODUCTION	6-1
6.2 SUPPLEMENTAL INFORMATION	6-1
6.3 OPERATING SPECIFICATIONS	6-2
Dimensional Data	6-5
Capacities	6-5
Tires	6-6
Engine	6-7
Batteries (Electric Machines)	6-7
Critical Stability Weights	6-8
Lubrication	6-11
6.4 OPERATOR MAINTENANCE	6-12
6.5 TIRES AND WHEELS	6-14
Tire Damage	6-14
Tire Replacement	6-14
Wheel Replacement	6-15
Wheel Installation	6-15

SECTION - 7 - INSPECTION AND REPAIR LOG

TABLE OF CONTENTS

SECTION - PARAGRAPH, SUBJECT	PAGE
LIST OF FIGURES	
2-1. Walk-Around Inspection (Sheet 1 of 3)	2-8
2-2. Walk-Around Inspection (Sheet 2 of 3)	2-9
2-3. Walk-Around Inspection (Sheet 3 of 3)	2-10
2-4. Limit Switch Locations	2-11
3-1. Ground Control Station	3-2
3-2. Platform Control Station	3-6
3-3. Indicator Panel	3-7
3-4. Decal Installation (ANSI)	3-8
3-5. Decal Installation (ANSI Export)	3-11
3-6. Decal Installation (CE/AUS)	3-17
4-1. Grade and Sideslope	4-3
4-2. Lifting & Tie Down Chart - Sheet 1 of 2	4-6
4-3. Lifting & Tie Down Chart - Sheet 2 of 2	4-7
6-1. Engine Operating Temperature Specifications - (Kubota) Sheet 1 of 2	6-9
6-2. Engine Operating Temperature Specifications - (Kubota) Sheet 2 of 2	6-10
6-3. Operator Maintenance and Lubrication Diagram .	6-12

SECTION - PARAGRAPH, SUBJECT	PAGE
LIST OF TABLES	
1-1 Minimum Approach Distances (M.A.D.)	1-6
2-1 Inspection and Maintenance Table	2-3
2-2 Drive Limits	2-6
2-3 Tilt vs. Height	2-6
3-1 Decal Location Legend (ANSI)	3-9
3-2 Decal Location Legend (ANSI Export)	3-12
3-3 Decal Location Legend (CE/AUS)	3-18
6-1 Operating Specifications	6-2
6-2 Dimensional Data	6-5
6-3 Capacities	6-5
6-4 Tire Specifications	6-6
6-5 Engine Specifications	6-7
6-6 Engine Battery Specifications	6-7
6-7 Battery Specifications	6-7
6-8 Critical Stability Weights	6-8
6-9 Hydraulic Oil	6-11
6-10 Lubrication Specifications	6-11
6-11 Wheel Torque Chart	6-16
7-1 Inspection and Repair Log	7-1

TABLE OF CONTENTS

SECTION - PARAGRAPH, SUBJECT

PAGE

SECTION - PARAGRAPH, SUBJECT

PAGE

This page left blank intentionally.

SECTION 1. SAFETY PRECAUTIONS

1.1 GENERAL

This section outlines the necessary precautions for proper and safe machine usage and maintenance. In order to promote proper machine usage, it is mandatory that a daily routine is established based on the content of this manual. A maintenance program, using the information provided in this manual and the Service and Maintenance Manual, must also be established by a qualified person and must be followed to ensure that the machine is safe to operate.

The owner/user/operator/lessor/lessee of the machine should not accept operating responsibility until this manual has been read, training is accomplished, and operation of the machine has been completed under the supervision of an experienced and qualified operator.

These sections contain the responsibilities of the owner, user, operator, lessor, and lessee concerning safety, training, inspection, maintenance, application, and operation. If there are any questions with regard to safety, training, inspection, maintenance, application, and operation, please contact JLG Industries, Inc. ("JLG").

⚠ WARNING

FAILURE TO COMPLY WITH THE SAFETY PRECAUTIONS LISTED IN THIS MANUAL COULD RESULT IN MACHINE DAMAGE, PROPERTY DAMAGE, PERSONAL INJURY OR DEATH.

1.2 PRE-OPERATION

Operator Training and Knowledge

- The Operators and Safety Manual must be read in its entirety before operating the machine. For clarification, questions, or additional information regarding any portions of this manual, contact JLG Industries, Inc.

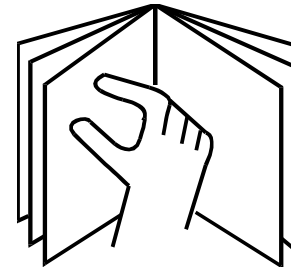

SECTION 1 - SAFETY PRECAUTIONS

- An operator must not accept operating responsibilities until adequate training has been given by competent and authorized persons.
- Allow only those authorized and qualified personnel to operate the machine who have demonstrated that they understand the safe and proper operation and maintenance of the unit.
- Read, understand, and obey all DANGERS, WARNINGS, CAUTIONS, and operating instructions on the machine and in this manual.
- Ensure that the machine is to be used in a manner which is within the scope of its intended application as determined by JLG.
- All operating personnel must be familiar with the emergency controls and emergency operation of the machine as specified in this manual.
- Read, understand, and obey all applicable employer, local, and governmental regulations as they pertain to your utilization and application of the machine.
- Do not operate or raise the platform from a position on trucks, trailers, railway cars, floating vessels, scaffolds or other equipment unless the application is approved in writing by JLG.
- Before operation, check work area for overhead hazards such as electric lines, bridge cranes, and other potential overhead obstructions.
- Check floor surfaces for holes, bumps, drop-offs, obstructions, debris, concealed holes, and other potential hazards.
- Check the work area for hazardous locations. Do not operate the machine in hazardous environments unless approved for that purpose by JLG.
- Ensure that the ground conditions are adequate to support the maximum tire load indicated on the tire load decals located on the chassis adjacent to each wheel.
- Do not operate the machine when wind conditions exceed 28 mph (12.5 m/s).
- This machine can be operated in nominal ambient temperatures of 0° F to 104° F (-20° C to 40° C). Consult JLG to optimize operation outside of this temperature range.

Workplace Inspection

- Precautions to avoid all hazards in the work area must be taken by the user before operation of the machine.

Machine Inspection

- Do not operate this machine until the inspections and functional checks have been performed as specified in Section 2 of this manual.
- Do not operate this machine until it has been serviced and maintained according to the maintenance and inspection requirements as specified in the machine's Service and Maintenance Manual.
- Ensure all safety devices are operating properly. Modification of these devices is a safety violation.

WARNING

MODIFICATION OR ALTERATION OF AN AERIAL WORK PLATFORM SHALL BE MADE ONLY WITH PRIOR WRITTEN PERMISSION FROM THE MANUFACTURER

- Do not operate any machine on which the safety or instruction placards or decals are missing or illegible.
- Check the machine for modifications to original components. Ensure that any modifications have been approved by JLG.
- Avoid accumulation of debris on platform deck. Keep mud, oil, grease, and other slippery substances from footwear and platform deck.

1.3 OPERATION

General

- Do not use the machine for any purpose other than positioning personnel, their tools, and equipment.
- Before operation, the user must be familiar with the machine capabilities and operating characteristics of all functions.
- Never operate a malfunctioning machine. If a malfunction occurs, shut down the machine. Remove the unit from service and notify the proper authorities.
- Do not remove, modify, or disable any safety devices.
- Never slam a control switch or lever through neutral to an opposite direction. Always return switch to neutral and stop before moving the switch to the next function. Operate controls with slow and even pressure.
- Hydraulic cylinders, other than the outrigger cylinders, should never be left at end of travel (fully extended or fully retracted) before shutdown or for long periods of time. Always "bump" control in opposite direction slightly when function reaches end of travel. This applies both to machines in operation or in the stowed position.

SECTION 1 - SAFETY PRECAUTIONS

- Do not allow personnel to tamper with or operate the machine from the ground with personnel in the platform, except in an emergency.
- Do not carry materials directly on platform railing unless approved by JLG.
- When two or more persons are in the platform, the operator shall be responsible for all machine operations.
- Always ensure that power tools are properly stowed and never left hanging by their cord from the platform work area.
- Do not assist a stuck or disabled machine by pushing or pulling except by pulling at the chassis tie-down lugs.
- Stow scissor arm assembly and shut off all power before leaving machine.

Trip and Fall Hazards

- JLG Industries, Inc. recommends that all persons in the platform wear a full body harness with a lanyard attached to an authorized lanyard anchorage point while operating this machine. For further information regarding fall protection requirements on JLG products, contact JLG Industries, Inc.

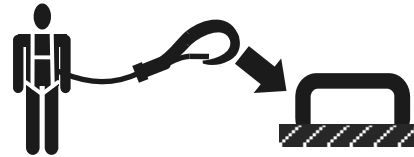

- Prior to operation, ensure all gates and rails are fastened and secured in their proper position. Identify the designated lanyard anchorage point(s) at the platform and securely attach the lanyard. Attach only one (1) lanyard per lanyard anchorage point

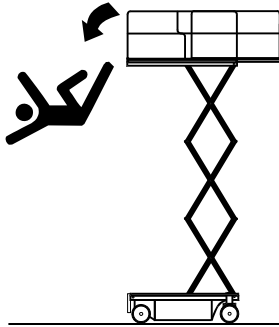

- Keep both feet firmly positioned on the platform floor at all times. Never position ladders, boxes, steps, planks, or similar items on unit to provide additional reach for any purpose.
- Never use the scissor arm assembly to gain access to or leave the platform.
- Use extreme caution when entering or leaving platform. Ensure that the scissor arm assembly is fully lowered. Face the machine when entering or leaving the platform. Always maintain “three point contact” with the machine, using two hands and one foot or two feet and one hand at all times during entry and exit.
- Keep oil, mud, and slippery substances cleaned from footwear and the platform floor.

Electrocution Hazards

- This machine is not insulated and does not provide protection from contact or proximity to electrical current.

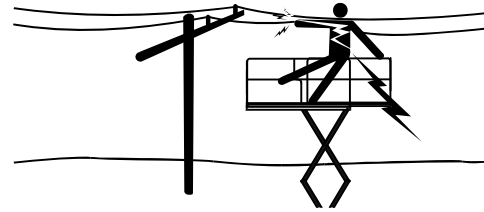

SECTION 1 - SAFETY PRECAUTIONS

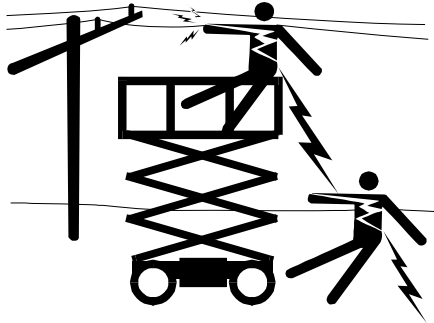

- Maintain safe clearance from electrical lines, apparatus, or any energized (exposed or insulated) parts in accordance with the Minimum Approach Distance (MAD) as specified in Table 1-1.
- Allow for machine movement and electrical line swaying.

Table 1-1. Minimum Approach Distances (M.A.D.)

Voltage Range (Phase to Phase)	MINIMUM APPROACH DISTANCE in Feet (Meters)
0 to 50KV	10 (3)
Over 50V to 200 KV	15 (5)
Over 200KV to 350 KV	20 (6)
Over 350 KV to 500 KV	25 (8)
Over 500 KV to 750 KV	35 (11)
Over 750 KV to 1000 KV	45 (14)

NOTE: *This requirement shall apply except where employer, local or governmental regulations are more stringent.*

- Maintain a clearance of at least 10 ft. (3m) between any part of the machine and its occupants, their tools, and their equipment from any electrical line or apparatus carrying up to 50,000 volts. One foot additional clearance is required for every additional 30,000 volts or less.

- The minimum approach distance may be reduced if insulating barriers are installed to prevent contact, and the barriers are rated for the voltage of the line being guarded. These barriers shall not be part of (or attached to) the machine. The minimum approach distance shall be reduced to a distance within the designed working dimensions of the insulating barrier. This determination shall be made by a qualified person in accordance with the employer, local, or governmental requirements for work practices near energized equipment.

⚠ DANGER

DO NOT MANEUVER MACHINE OR PERSONNEL INSIDE PROHIBITED ZONE (MAD). ASSUME ALL ELECTRICAL PARTS AND WIRING ARE ENERGIZED UNLESS KNOWN OTHERWISE.

Tipping Hazards

- Ensure that the ground conditions are adequate to support the maximum tire load indicated on the tire load decals located on the chassis adjacent to each wheel. Do not travel on unsupported surfaces.
- The user should be familiar with the driving surface before driving. Do not exceed the allowable sideslope and grade while driving

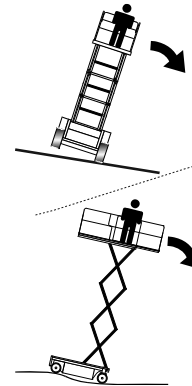

- Do not elevate platform or drive with platform elevated while on or near a sloping, uneven, or soft surface. Ensure machine is positioned on a firm, level and uniformly supported surface before elevating platform or driving with the platform in the elevated position.
- Before driving on floors, bridges, trucks, and other surfaces, check allowable capacity of the surfaces.
- Never exceed the maximum work load as specified on the platform. Keep all loads within the confines of the platform, unless authorized by JLG.

SECTION 1 - SAFETY PRECAUTIONS

- Keep the chassis of the machine a minimum of 2 ft (0.6 m) from holes, bumps, drop-offs, obstructions, debris, concealed holes, and other potential hazards at the ground level.
- Never attempt to use the machine as a crane. Do not tie-off machine to any adjacent structure. Never attach wire, cable, or any similar items to platform.
- Do not cover the platform sides or carry large surface-area items in the platform when operating outdoors. The addition of such items increases the exposed wind area of the machine.
- Do not increase the platform size with unauthorized deck extensions or attachments.
- If scissor arm assembly or platform is caught so that one or more wheels are off the ground, all persons must be removed before attempting to free the machine. Use cranes, forklift trucks, or other appropriate equipment to stabilize machine and remove personnel.

Crushing and Collision Hazards

- Approved head gear must be worn by all operating and ground personnel.
- Keep hands and limbs out of the scissor arm assembly during operation.

- Watch for obstructions around machine and overhead when driving. Check clearances above, on sides, and bottom of platform when lifting or lowering platform.

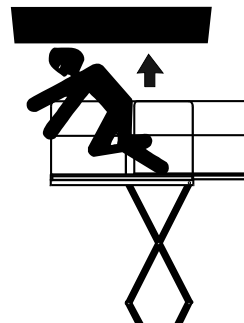

- During operation, keep all body parts inside platform railing.
- Always post a lookout when driving in areas where vision is obstructed.
- Keep non-operating personnel at least 6 ft (1.8 m) away from machine during all driving operations.
- Under all travel conditions, the operator must limit travel speed according to conditions of ground surface, congestion, visibility, slope, location of personnel, and other factors causing hazards of collision or injury to personnel.

- Be aware of stopping distances in all drive speeds. When driving in high speed, switch to low speed before stopping. Travel grades in low speed only.
- Do not use high speed drive in restricted or close quarters or when driving in reverse.
- Exercise extreme caution at all times to prevent obstacles from striking or interfering with operating controls and persons in the platform.
- Ensure that operators of other overhead and floor level machines are aware of the aerial work platform's presence. Disconnect power to overhead cranes. Barricade floor area if necessary.
- Avoid operating over ground personnel. Warn personnel not to work, stand, or walk under a raised platform. Position barricades on floor as necessary.
- Ensure platform is fully retracted and completely empty of tools prior to towing, lifting or hauling.
- When lifting machine with a forklift, position forks only at designated areas of the machine. Lift with a forklift of adequate capacity.
- Refer to Section 4 for lifting information.

1.4 TOWING, LIFTING, AND HAULING

- Never allow personnel in platform while towing, lifting, or hauling.
- This machine should not be towed, except in the event of emergency, malfunction, power failure, or loading/unloading. Refer to emergency towing procedures.

1.5 MAINTENANCE

General

This section contains general safety precautions which must be observed during maintenance of this machine. Additional precautions to be observed during machine maintenance are inserted at the appropriate points in this manual and in the Service and Maintenance Manual. It is of utmost importance that maintenance personnel pay strict attention to these precautions to avoid possible injury to personnel or damage to the machine or property. A maintenance program must be established by a qualified person and must be followed to ensure that the machine is safe.

SECTION 1 - SAFETY PRECAUTIONS

Maintenance Hazards

- Shut off power to all controls and ensure that all operating systems are secured from inadvertent motion prior to performing any adjustments or repairs.
- Never work under an elevated platform until it has been fully lowered to the full down position, if possible, or otherwise supported and restrained from movement with appropriate safety props, blocking, or overhead supports.
- Always relieve hydraulic pressure from all hydraulic circuits before loosening or removing hydraulic components.
- Always disconnect batteries when servicing electrical components or when performing welding on the machine.
- Shut down the engine (if equipped) while fuel tanks are being filled.
- Ensure replacement parts or components are identical or equivalent to original parts or components.
- Never attempt to move heavy parts without the aid of a mechanical device. Do not allow heavy objects to rest in an unstable position. Ensure adequate support is provided when raising components of the machine.
- Remove all rings, watches, and jewelry when performing any maintenance. Do not wear loose fitting clothing or

long hair unrestrained which may become caught or entangled in equipment.

- Use only clean approved non-flammable cleaning solvents.
- Never alter, remove, or substitute any items such as counterweights, tires, batteries, platforms or other items that may reduce or affect the overall weight or stability of the machine.
- Reference the Service and Maintenance Manual for the weights of critical stability items.

WARNING

MODIFICATION OR ALTERATION OF AN AERIAL WORK PLATFORM SHALL BE MADE ONLY WITH PRIOR WRITTEN PERMISSION FROM THE MANUFACTURER.

Battery Hazards

- Always disconnect batteries when servicing electrical components or when performing welding on the machine.
- Do not allow smoking, open flame, or sparks near battery during charging or servicing.
- Do not contact tools or other metal objects across the battery terminals.

- Always wear hand, eye, and face protection when servicing batteries. Ensure that battery acid does not come in contact with skin or clothing.

 **WARNING**

BATTERY FLUID IS HIGHLY CORROSIVE. AVOID CONTACT WITH SKIN AND CLOTHING AT ALL TIMES. IMMEDIATELY RINSE ANY CONTACTED AREA WITH CLEAN WATER AND SEEK MEDICAL ATTENTION.

- Charge batteries only in a well ventilated area.
- Avoid overfilling the battery fluid level. Add distilled water to batteries only after the batteries are fully charged.

SECTION 1 - SAFETY PRECAUTIONS



NOTES:

SECTION 2. USER RESPONSIBILITIES, MACHINE PREPARATION AND INSPECTION

2.1 PERSONNEL TRAINING

The aerial platform is a personnel handling device; so it is necessary that it be operated and maintained only by trained personnel.

Persons under the influence of drugs or alcohol or who are subject to seizures, dizziness or loss of physical control must not operate this machine.

Operator Training

Operator training must cover:

1. Use and limitations of the controls in the platform and at the ground, emergency controls and safety systems.
2. Control labels, instructions, and warnings on the machine.
3. Rules of the employer and government regulations.
4. Use of approved fall protection equipment.
5. Enough knowledge of the mechanical operation of the machine to recognize a malfunction or potential malfunction.
6. The safest means to operate the machine where overhead obstructions, other moving equipment, and obstacles, depressions, holes, drop-offs.
7. Means to avoid the hazards of unprotected electrical conductors.
8. Specific job requirements or machine application.

Training Supervision

Training must be done under the supervision of a qualified person in an open area free of obstructions until the trainee has developed the ability to safely control and operate the machine.

Operator Responsibility

The operator must be instructed that he/she has the responsibility and authority to shut down the machine in case of a malfunction or other unsafe condition of either the machine or the job site.

2.2 PREPARATION, INSPECTION, AND MAINTENANCE

The following table covers the periodic machine inspections and maintenance recommended by JLG Industries, Inc. Consult local regulations for further requirements for aerial work platforms. The frequency of inspections and maintenance must be increased as necessary when the machine is used in a harsh or hostile environment, if the machine is used with increased frequency, or if the machine is used in a severe manner.

NOTICE

JLG INDUSTRIES, INC. RECOGNIZES A FACTORY-CERTIFIED SERVICE TECHNICIAN AS A PERSON WHO HAS SUCCESSFULLY COMPLETED THE JLG SERVICE TRAINING SCHOOL FOR THE SPECIFIC JLG PRODUCT MODEL.

SECTION 2 - USER RESPONSIBILITIES, MACHINE PREPARATION AND INSPECTION

Table 2-1. Inspection and Maintenance Table

Type	Frequency	Primary Responsibility	Service Qualification	Reference
Pre-Start Inspection	Before using each day; or whenever there's an Operator change.	User or Operator	User or Operator	Operator and Safety Manual
Pre-Delivery Inspection (See Note)	Before each sale, lease, or rental delivery.	Owner, Dealer, or User	Qualified JLG Mechanic	Service and Maintenance Manual and applicable JLG inspection form
Frequent Inspection	In service for 3 months or 150 hours, whichever comes first; or Out of service for a period of more than 3 months; or Purchased used.	Owner, Dealer, or User	Qualified JLG Mechanic	Service and Maintenance Manual and applicable JLG inspection form
Annual Machine Inspection (See Note)	Annually, no later than 13 months from the date of prior inspection.	Owner, Dealer, or User	Factory Certified Service Technician (Recommended)	Service and Maintenance Manual and applicable JLG inspection form
Preventative Maintenance	At intervals as specified in the Service and Maintenance Manual.	Owner, Dealer, or User	Qualified JLG Mechanic	Service and Maintenance Manual

NOTE: *Inspection forms are available from JLG. Use the Service and Maintenance Manual to perform inspections.*

SECTION 2 - USER RESPONSIBILITIES, MACHINE PREPARATION AND INSPECTION

2.3 PRE-START INSPECTION

The Pre-Start Inspection should include each of the following:

1. **Cleanliness** – Check all surfaces for leakage (oil, fuel, or battery fluid) or foreign objects. Report any leakage to the proper maintenance personnel.
2. **Structure** - Inspect the machine structure for dents, damage, weld or parent metal cracks or other discrepancies.

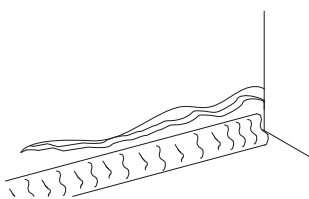

Parent Metal Crack

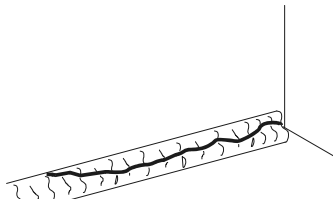

Weld Crack

3. **Decals and Placards** – Check all for cleanliness and legibility. Make sure none of the decals and placards are missing. Make sure all illegible decals and placards are cleaned or replaced.

4. **Operators and Safety Manuals** – Make sure a copy of the Operator and Safety Manual is enclosed in the weather resistant storage container.
5. **“Walk-Around” Inspection** – Refer to Figure 2-1., Walk-Around Inspection (Sheet 1 of 3).
6. **Battery** – Charge as required.
7. **Fuel** - (Combustion Engine Powered Machines) – Add the proper fuel as necessary.
8. **Engine Oil Supply** - Ensure that the engine oil level is at the full mark on the dipstick and the filler cap is secure
9. **Fluid Levels** - Be sure to check the engine oil and the hydraulic oil levels.
10. **Accessories/Attachments** - Reference the Operator and Safety Manual of each attachment or accessory installed upon the machine for specific inspection, operation, and maintenance instructions.
11. **Function Check** – Once the “Walk-Around” Inspection is complete, perform a functional check of all systems in an area free of overhead and ground level obstructions. Refer to Section 4 for more specific instructions on the operation of each function.

Preparing the Machine for Operation

Emergency Ground Control Station

1. Turn key-switch to ground control select.
2. Pull emergency stop switch to the On position.
3. Check the function of the protective scissor cage.

Platform Control Box

1. Ensure the control box is connected at the platform.
2. Complete pre-operational checks:
 - Check all functions
 - Machine should not be drivable with outriggers extended.
 - Check all limit switches
 - Check the emergency-STOP button
 - Check the automatic self levelling

WARNING

IF THE MACHINE DOES NOT OPERATE PROPERLY, TURN OFF THE MACHINE IMMEDIATELY! REPORT THE PROBLEM TO THE PROPER MAINTENANCE PERSONNEL. DO NOT OPERATE THE MACHINE UNTIL IT IS DECLARED SAFE FOR OPERATION.

Function Check

Perform the Function Check as follows:

1. From the ground emergency control panel with no load in the platform:
 - a. Check for proper lifting and lowering of the platform.
 - b. Check manual descent.
 - c. Ensure that all machine functions are disabled when the Emergency Stop Button is activated.

NOTE: *Be sure the platform extension is retracted before lowering.*

2. From the platform control console:
 - a. Ensure that the control console is firmly secured in the proper location.
 - b. Check that all guards protecting the function control switches are in place.
 - c. Check the high drive cut out switch by raising the platform beyond the preset high drive speed cutout height (stowed) and ensure the high drive speed cuts out.
 - d. Ensure that all machine functions are disabled when the Emergency Stop Button is pushed in.

SECTION 2 - USER RESPONSIBILITIES, MACHINE PREPARATION AND INSPECTION

- e. Ensure that all LED's in the control box are working properly.
 - f. Check that the platform extension extends and retracts properly.
3. With the platform in the stowed position:
- a. Drive the machine on a grade, not to exceed the rated gradeability, and stop to ensure the brakes hold.
 - b. The red warning LED on the control panel indicates the chassis is on a slope beyond the rated limit from side to side and/or front to rear when the platform is in the stowed position.

Table 2-2. Drive Limits

Model	High Drive Cutout	Drive Cutout	Drive at Creep Speed
3369LE/M3369	Above Stowed	N/A	N/A
4069LE/M4069	Above Stowed	30 ft (9.1 m)	N/A
M4069 (AUS Full Drive Height Model)	Above Stowed	N/A	28 ft - 30 ft (8.5 m - 9.1 m)

Table 2-3. Tilt vs. Height

Height	Tilt	
	Left - Right	Front - Back
3369LE/M3369 (ANSI/CE/Australia/Japan)		
< 25 ft (7.6 m)	5°	5°
< 30 ft (9.1 m)	4°	5°
Full Height	3°	5°
3369LE/M3369 (CSA)		
Full Height	3°	3°
3369LE/M3369 (CE) - 37 mph (16.7 m/s) windspeed option		
< 25 ft (7.6 m)	4°	5°
Full Height	2°	4°
4069LE/M4069 (ANSI/CE/Australia/Japan)		
< 30 ft (9.1 m)	5°	5°
< 36 ft (11 m)	4°	5°
Full Height	3°	5°
4069LE/M4069 (CSA)		
Full Height	3°	3°

NOTE: When the limits are exceeded, drive and lift-up functions are cutout.

2.4 OSCILLATING AXLE LOCKOUT TEST (IF EQUIPPED)

NOTICE

LOCKOUT SYSTEM TEST MUST BE PERFORMED QUARTERLY, ANY TIME A SYSTEM COMPONENT IS REPLACED, OR WHEN IMPROPER SYSTEM OPERATION IS SUSPECTED.

NOTE: *Ensure platform is fully lowered prior to beginning lockout cylinder test.*

1. Place a 6 inch (15.2 cm) high block with ascension ramp in front of left front wheel.
2. From platform control station, select LOW drive speed.
3. Place DRIVE control switch to FORWARD position and carefully drive the machine up ascension ramp until left front wheel is on top of block.
4. Raise machine platform approximately 7 ft (2.1 m) on the 3369LE or 9 ft (2.7 m) on the 4069LE.
5. Place DRIVE control switch to REVERSE position and carefully drive the machine off the block and ramp.
6. Have an assistant check to see that the left front wheel remains locked in position off the ground.
7. Lower the machine platform; the lockout cylinder should then release and allow wheel to rest on the ground. It may be necessary to activate DRIVE to release cylinders.
8. Place the 6 inch (15.2 cm) high block with ascension ramp in front of right front wheel.
9. From platform control station, select LOW drive speed.
10. Place DRIVE control switch to FORWARD position and carefully drive the machine up ascension ramp until right front wheel is on top of block.
11. Raise machine platform approximately 7 ft (2.1 m) on the 3369LE or 9 ft (2.7 m) on the 4069LE.
12. Place DRIVE control switch to REVERSE position and carefully drive the machine off the block and ramp.
13. Have an assistant check to see that the right front wheel remains locked in position off the ground.
14. Lower the machine platform; the lockout cylinder should then release and allow wheel to rest on the ground. It may be necessary to activate DRIVE to release cylinders.
15. If the lockout cylinders do not function properly, have qualified personnel correct the malfunction prior to any further operation.

SECTION 2 - USER RESPONSIBILITIES, MACHINE PREPARATION AND INSPECTION

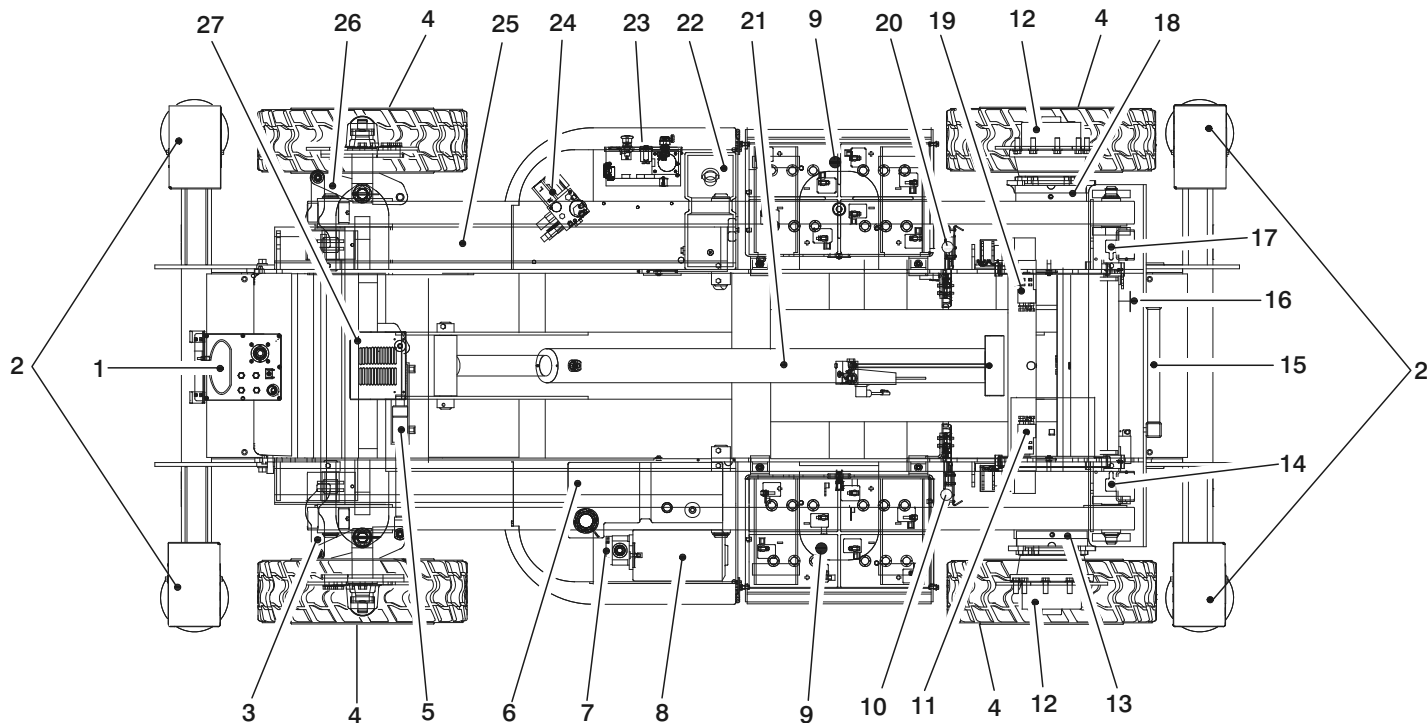

Figure 2-1. Walk-Around Inspection (Sheet 1 of 3)

SECTION 2 - USER RESPONSIBILITIES, MACHINE PREPARATION AND INSPECTION

GENERAL

Begin the “Walk-Around Inspection” at Item 1, as noted on the diagram. Continue Left (counterclockwise viewed from top) checking each item in sequence for the conditions listed in the following checklist.

WARNING

TO AVOID POSSIBLE INJURY, BE SURE MACHINE POWER IS “OFF” DURING “WALK-AROUND INSPECTION”.

NOTICE

DO NOT OVERLOOK VISUAL INSPECTION OF CHASSIS UNDERSIDE. CHECKING THIS AREA OFTEN RESULTS IN DISCOVERY OF CONDITIONS WHICH COULD CAUSE EXTENSIVE MACHINE DAMAGE.

NOTE: *On each item, make sure there are no loose or missing parts, that they are securely fastened, and that no visible damage exists in addition to any other criteria mentioned.*

1. Platform Control Console - Placard secure and legible, control lever and switches return to neutral, con-

trol lever lock and emergency stop switch function properly, manual in storage box.

2. Leveling Jacks - See Note
3. Spindle, Tie Rod and Steer Linkage (left front) - See Note
4. Wheels and Tires - Properly secured, no missing lug nuts. Refer to section 6, Tires and Wheels. Inspect wheels for damage and corrosion
5. Steer Cylinder - See Note
6. Hydraulic Reservoir - Recommended hydraulic fluid level on level indicator on tank. Breather cap secure and working.
7. Hydraulic Pump - See Note
8. Hydraulic Motor - See Note
9. Battery Compartment - Proper electrolyte level.
10. Battery Disconnect - See Note
11. Oscillating Axle, Oscillation Cylinder - See Note
12. Drive Hubs - See Note
13. Brake, Left Rear - See Note

Figure 2-2. Walk-Around Inspection (Sheet 2 of 3)

SECTION 2 - USER RESPONSIBILITIES, MACHINE PREPARATION AND INSPECTION

14. Limit Switch - See Note
15. Ladder - See Note
16. Manual Descent - See Note
17. Limit Switch - See Note
18. Brake, Right Rear - See Note
19. Oscillation Cylinder - See Note
20. Battery Disconnect - See Note
21. Lift Cylinder - See Note
22. Generator Fuel Supply - See Note
23. Ground Controls - Placard secure and legible, control switches return to neutral position, emergency stop switch functions properly. Control markings legible.
24. Control Valve - No unsupported wires or hoses; no damaged or broken wires.
25. Sizzor Arms and Sliding Wear Pads - See Note
26. Spindle, Tie Rod and Steer Linkage (right front) - See Note
27. Battery Charger - See Note
28. Platform/Handrail Installation (Not Shown) - See Note

Figure 2-3. Walk-Around Inspection (Sheet 3 of 3)

Limit Switch Locations

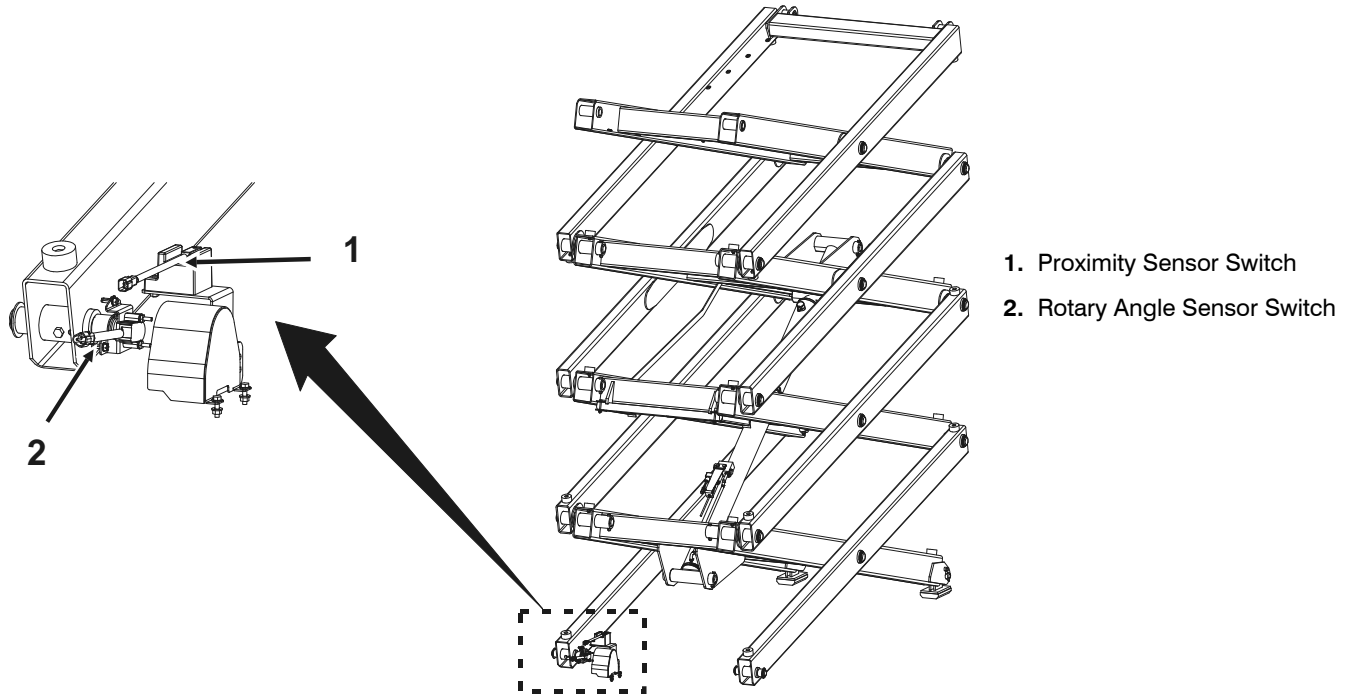

Figure 2-4. Limit Switch Locations

SECTION 2 - USER RESPONSIBILITIES, MACHINE PREPARATION AND INSPECTION



NOTES:

<hr/> <hr/> <hr/> <hr/> <hr/> <hr/> <hr/> <hr/> <hr/> <hr/> <hr/> <hr/> <hr/> <hr/> <hr/> <hr/> <hr/> <hr/> <hr/> <hr/> <hr/> <hr/> <hr/>	<hr/> <hr/> <hr/> <hr/> <hr/> <hr/> <hr/> <hr/> <hr/> <hr/> <hr/> <hr/> <hr/> <hr/> <hr/> <hr/> <hr/> <hr/> <hr/> <hr/> <hr/> <hr/> <hr/>
---	---

SECTION 3. MACHINE CONTROLS AND INDICATORS

3.1 GENERAL

NOTICE

THE MANUFACTURER HAS NO DIRECT CONTROL OVER MACHINE APPLICATION AND OPERATION. THE USER AND OPERATOR ARE RESPONSIBLE FOR CONFORMING WITH GOOD SAFETY PRACTICES.

This section provides the necessary information needed to understand control functions.

3.2 CONTROLS AND INDICATORS

Ground Control Station

⚠ WARNING

DO NOT OPERATE FROM GROUND CONTROL STATION WITH PERSONNEL IN PLATFORM EXCEPT IN AN EMERGENCY.

NOTE: *When machine is shut down, the ground control emergency stop switch must be positioned to OFF to prevent draining the batteries.*

1. Power/Emergency Stop

A two-position red mushroom shaped switch furnishes power to Platform/Ground Select switch when pulled out (on). When pushed in (off), power is shut off to the Platform/Ground Select switch.

2. Platform/Ground Select

A three position, key operated switch supplies power to platform control console when positioned to platform. With the key held in the ground position, power is shut off to platform and only ground controls are operable.

NOTE: *With Platform/Ground Select in center position, power is shut off to controls at both operating stations.*

3. Lift/Lower

A three position, momentary contact lift control switch provides raising and lowering of the platform when positioned to up or down.

4. Generator Start Switch (Optional)

A momentary contact, push button switch is provided to manually start the optional generator

SECTION 3 - MACHINE CONTROLS AND INDICATORS

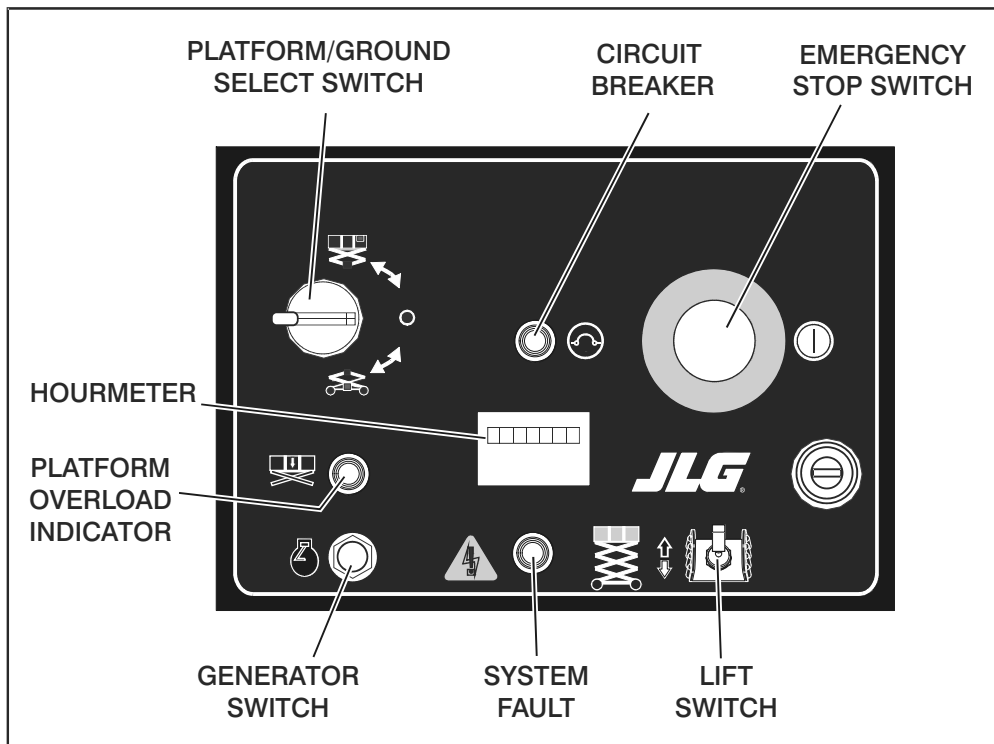

Figure 3-1. Ground Control Station

5. Platform Overload Indicator (If Equipped)

Indicates the platform has been overloaded. An audible alarm will also signal when the platform is overloaded.

NOTE: *If the Overload Indicator is illuminated, all functions will be prevented from the platform controls. Using the ground controls or manual descent, fully lower the machine and reduce the weight in the platform so as to not exceed the rated workload indicated on the capacity decal.*

6. Hourmeter

The hourmeter indicates the number of hours the machine has been operated.

7. Circuit Breaker

If the circuit breaker opens this indicates a short or overload on the machine.

8. System Fault

Illuminates when there is any type of fault in the electrical system.

Platform Control Station

1. Power/Emergency Stop

A two-position red mushroom shaped switch furnishes power to Platform/Ground Select switch when pulled out (on). When pushed in (off), power is shut off to the Platform/Ground Select switch.

2. Controller (Joystick)

The Joystick controls four functions: drive, steer, lift and optional outriggers. The drive or the lift function switch must be selected before operating the joystick. The controller is 'ramped' to allow variable speed.

3. Steer

Steering is controlled by a thumb-operated switch on top of the Joystick.

4. Low/High Speed

The two position speed switch controls high or low range travel speed.

NOTE: *Travel speed will automatically be reduced to low drive when the platform is raised above the stowed position. For M4069 (AUS Full Drive Height Model), low drive speed is cut back to creep drive speed above 28 - 30 ft (8.5 - 9.1 m) up to the maximum height of 40 ft (12.2 m).*

SECTION 3 - MACHINE CONTROLS AND INDICATORS

5. Drive Select

When selected, the drive function will be active for 3 seconds. The operator has 3 seconds to select the desired direction of travel.

WARNING

DO NOT OPERATE MACHINE IF HIGH DRIVE SPEED OPERATES WHEN PLATFORM IS RAISED ABOVE THE STOWED POSITION. FOR AUS FULL DRIVE HEIGHT MODEL, DO NOT OPERATE IF LOW DRIVE SPEED IS NOT CUT BACK TO CREEP DRIVE SPEED ONCE PLATFORM IS RAISED ABOVE 28 - 30 FT (8.5 - 9.1 M)

6. Lift /Lower

When selected, the lift function will be active for 3 seconds. The operator has 3 seconds to select the desired direction of lift.

WARNING

DO NOT LOWER WITHOUT COMPLETELY RETRACTING THE PLATFORM EXTENSION.

7. Leveling Jacks (Optional, Mandatory on M4069 AUS Full Drive Height Model)

When selected, the leveling jack function will be active for 3 seconds in order to raise or lower the jacks. Indicator lights will illuminate signaling the leveling jacks are being set or retracted. See Figure 3-3., Indicator Panel

8. Generator Enable Switch (Optional)

The Generator Enable Switch, when in the off position, allows the operator to prevent the generator engine from starting when using the machine indoors. When in the on position (and the ground Emergency Stop Switch on [pulled out]), the generator is enabled to automatically start when the batteries need charged.

9. All Wheel Drive (Optional)

Activating the All Wheel Drive switch allows the operator to engage the front drive motors for a pre-set time of 10 seconds. The control system may also engage the positrack function automatically. This occurs when the rear wheels begin to slip and the joystick is engaged at 75%. This is pre-set to remain engaged for 10 seconds.

NOTE: *All Wheel Drive does not aid in climbing a grade.*

10. Horn

If pressed, this switch supplies power to the horn.

11. Tilt Indicator Warning LED

The red warning LED on the control panel illuminates when the chassis is on a slope greater than what the machine is programmed for.

12. Tilt Alarm Warning Horn

The Tilt Alarm Warning Horn is activated when the chassis is on a slope greater than what the machine is programmed for and the platform is elevated.

13. Battery Charge Indicator

This indicates the level of charge remaining in the batteries.

SECTION 3 - MACHINE CONTROLS AND INDICATORS

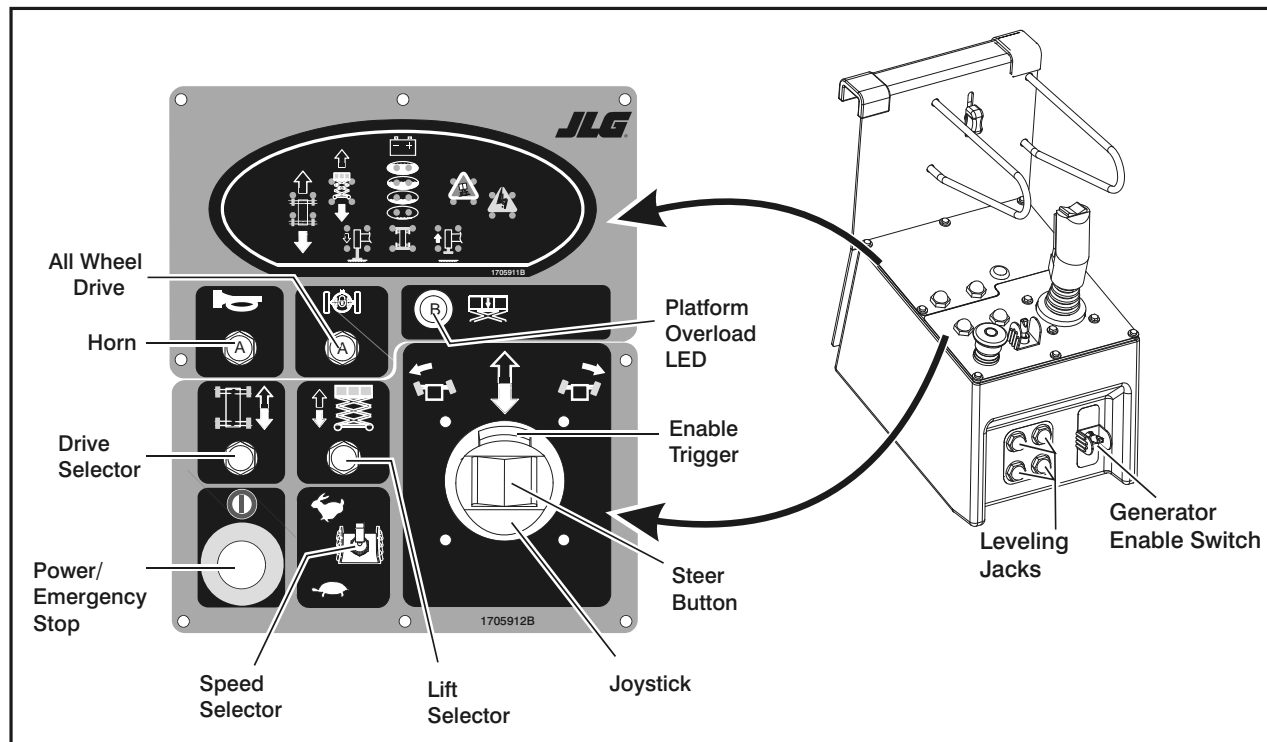

Figure 3-2. Platform Control Station

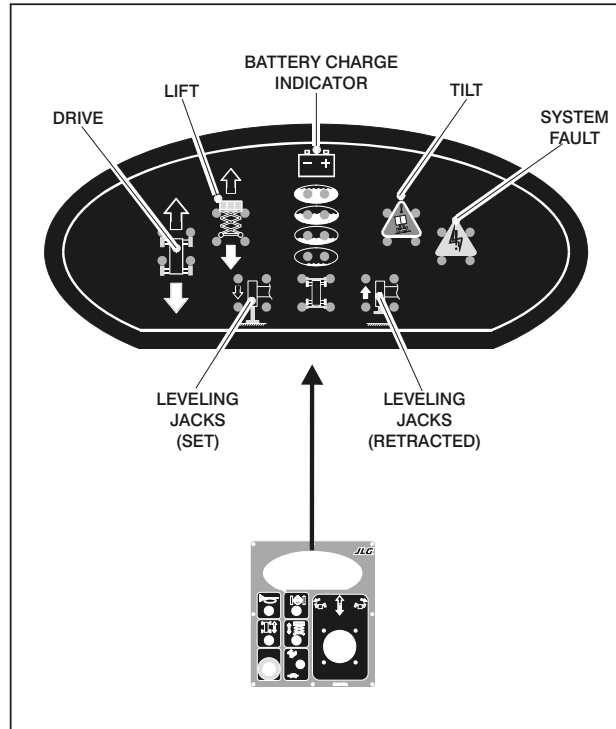

Figure 3-3. Indicator Panel

SECTION 3 - MACHINE CONTROLS AND INDICATORS

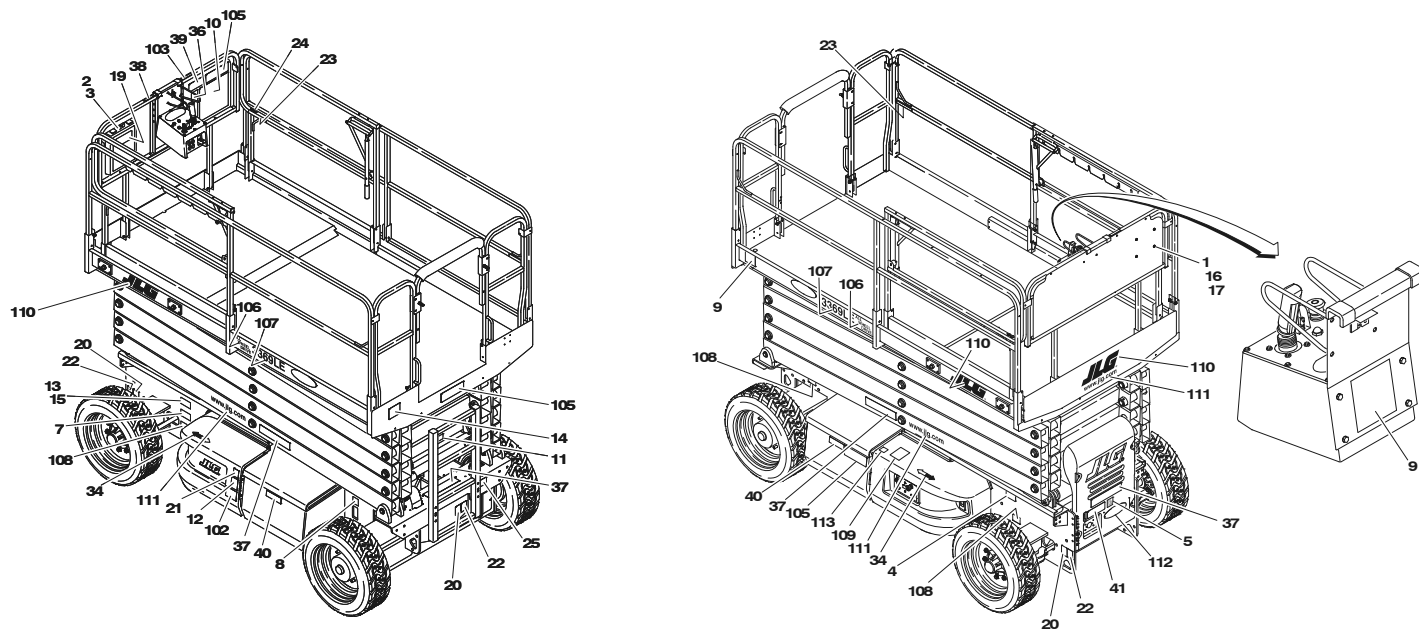

Figure 3-4. Decal Installation (ANSI)

SECTION 3 - MACHINE CONTROLS AND INDICATORS

Table 3-1. Decal Location Legend (ANSI)

Item	ANSI 0270591-6
1-3	--
4	1700584
5	1701644
6	--
7	1702153
8	1702155
9	--
10	1703816
11	1704211
12	1704412
13	--
14	3251813
15	--
16-18	--

Table 3-1. Decal Location Legend (ANSI)

Item	ANSI 0270591-6
19	
USA manufactured - Prior to S/N 0200101481	1703788
USA manufactured - S/N 0200101481 to present	1701509
Belgium Manufactured - S/N 1200000398 to present	1701509
20	1701500
21	1703812
22	1703814
23	1704277
24	1703819
25	1703822
26 to 33	--
34	1703687
35	--
36	1704911
37	1703818

SECTION 3 - MACHINE CONTROLS AND INDICATORS

Table 3-1. Decal Location Legend (ANSI)

Item	ANSI 0270591-6
38	1703821
39	1704903
40	1703813
41	1704248
101	--
102	1704174
103 (M3369/M4069 ANSI California Spec only)	1702962
104	--
105 3369LE & M3369 4069LE & M4069	1001125438 1001125437
106 (4WD only)	1704998
107 3369LE 4069LE M3369 M4069	1704783 1704784 1704908 1704909

Table 3-1. Decal Location Legend (ANSI)

Item	ANSI 0270591-6
108 3369LE & M3369 4069LE & M4069	1703490 1704953
109 (M3369/M4069 only)	1704286
110	1702773
111	1704885
112	1704830
113 (M3369/M4069 only)	1701505

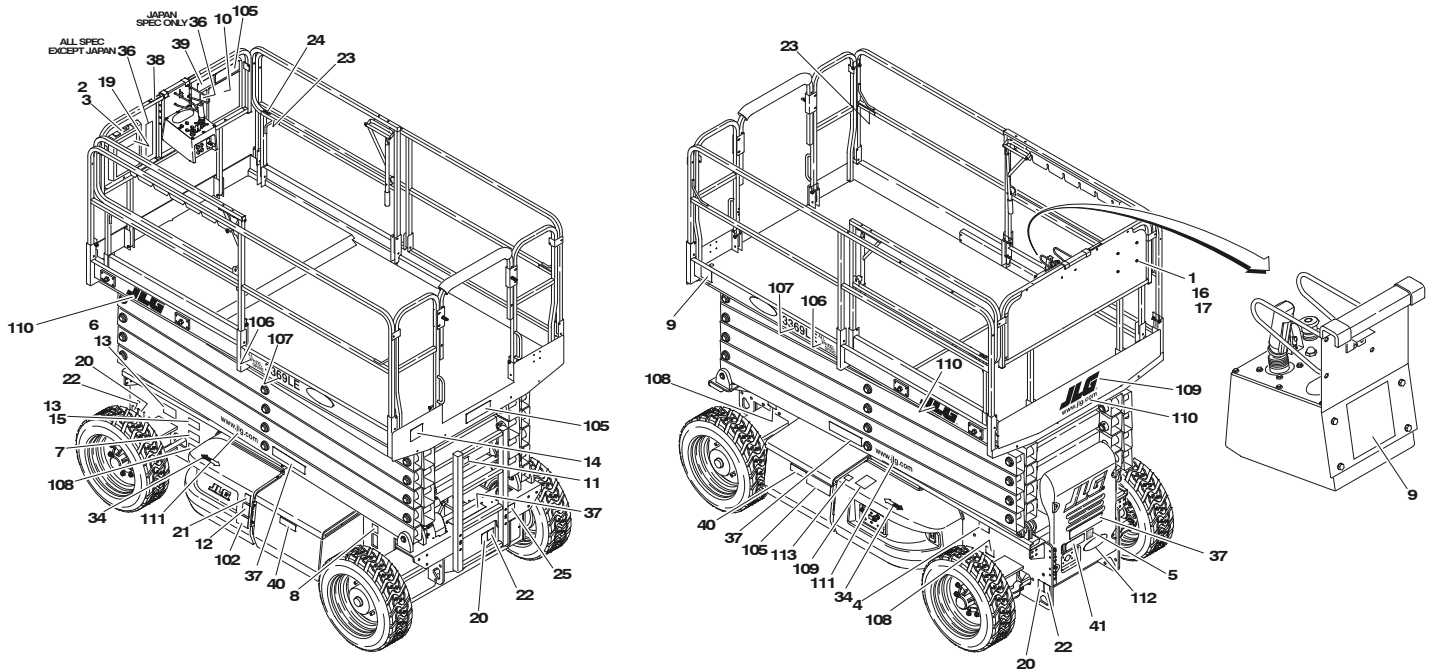

Figure 3-5. Decal Installation (ANSI Export)

SECTION 3 - MACHINE CONTROLS AND INDICATORS

Table 3-2. Decal Location Legend (ANSI Export)

Item #	Brazilian 0270601_5	Chinese 0272005_2	CSA 0272653_2	Japanese 0270602_2	Latin American 0270600_5	Korea 0275688_2
1-3	--	--	--	--	--	--
4	1700584	1700584	1700584	1700584	1700584	1700584
5	1701644	1701644	1701644	1701644	1701644	1701644
6	3252191	3252191	--	3252191	3252191	3252191
USA manufactured - Prior to S/N 0200108331						
USA manufactured - S/N 0200108331 to present	1705303	1705303	--	1705303	1705303	1705303
Belgium manufactured - Prior to S/N 1200000459	3252191	3252191	--	3252191	3252191	3252191
Belgium Manufactured - S/N 1200000459 to present	1705303	1705303	--	1705303	1705303	1705303

SECTION 3 - MACHINE CONTROLS AND INDICATORS

Table 3-2. Decal Location Legend (ANSI Export)

Item #	Brazilian 0270601_5	Chinese 0272005_2	CSA 0272653_2	Japanese 0270602_2	Latin American 0270600_5	Korea 0275688_2
7	1704008	1704607	1704007 (USA manufactured - Prior to S/N 0200108331) 1704006 (USA manufactured - S/ N 0200108331to present) 1704007 (Belgium manufactured - Prior to S/N 1200000459) 1704006 (Belgium Manufactured - S/N 1200000459 to present)	1701621	1704006	1703962
8	1702155	1702155	1702155	1702155	1702155	1702155
9	1702631	1702631	1702631	1702631	1702631	1702631
10	1704699	1705195	1704684	1704278	1704691	1707021

SECTION 3 - MACHINE CONTROLS AND INDICATORS

Table 3-2. Decal Location Legend (ANSI Export)

Item #	Brazilian 0270601_5	Chinese 0272005_2	CSA 0272653_2	Japanese 0270602_2	Latin American 0270600_5	Korea 0275688_2
11	1704211	1704211	1704211	1704211	1704211	1704211
12	1704412	1704412	1704412	1704412	1704412	1704412
13	--	--	--	--	--	--
14	3251813	3251813	3251813	3251813	3251813	3251813
15	3252645	3252645	3252645	3252645	3252645	3252645
16-17	--	--	--	--	--	--
18	2901912	2901912	2901912	2901912	2901912	2901912
19						
USA manufactured - Prior to S/N 0200101481	1703788	1703788	1703788	1703788	1703788	1703788
USA manufactured - S/N 0200101481 to present	1701509	1701509	1701509	1701509	1701509	1701509
Belgium Manufactured - S/N 1200000398 to present	1701509	1701509	1701509	1701509	1701509	1701509
20	1703811	1703811	1703811	1703811	1703811	1703811
21	1703812	1703812	1703812	1703812	1703812	1703812
22	1703814	1703814	1703814	1703814	1703814	1703814

SECTION 3 - MACHINE CONTROLS AND INDICATORS

Table 3-2. Decal Location Legend (ANSI Export)

Item #	Brazilian 0270601_5	Chinese 0272005_2	CSA 0272653_2	Japanese 0270602_2	Latin American 0270600_5	Korea 0275688_2
23	1704277	1704277	1704277	1704277	1704277	1704277
24	1703819	1703819	1703819	1703819	1703819	1703819
25	1703822	1703822	1703822	1703822	1703822	1703822
26-33	--	--	--	--	--	--
34	1703687	1703687	1703687	1703687	1703687	1703687
35	--	--	--	--	--	--
36	1704915	1705097	1704904	1704917	1704913	1707026
37	1704701	1705193	1704686	1705394	1704693	1707018
38	1704702	1705194	1704687	1705398	1704694	1707020
39	1704916	1705098	1704912	1704918	1704914	1707024
40	1704341	1704344	1704340	1704342	1704339	1707022
41	1704330	1704333	1704329	1704331	1704329	1707025
101	--	--	--	--	--	--
102	1704174	1704174	1704174	1704174	1704174	1704174
103-104	--	--	--	--	--	--
105 3369LE & M3369 4069LE & M4069	1001125438 1001125437					

SECTION 3 - MACHINE CONTROLS AND INDICATORS

Table 3-2. Decal Location Legend (ANSI Export)

Item #	Brazilian 0270601_5	Chinese 0272005_2	CSA 0272653_2	Japanese 0270602_2	Latin American 0270600_5	Korea 0275688_2
106 (4WD only)	1704998	1704998	1704998	1704998	1704998	1704998
107 3369LE 4069LE M3369 M4069	1704783 1704784 1704908 1704909	1704783 1704784 1704908 1704909	1704783 1704784 1704908 1704909	1704783 1704784 1704908 1704909	1704783 1704784 1704908 1704909	1704783 1704784 1704908 1704909
108 3369LE & M3369 4069LE & M4069	1703490 1704953	1703490 1704953	1703490 1704953	1703490 1704953	1703490 1704953	1703490 1704953
109 (M3369/M4069 only)	1704373	--	1704368	1704369	1704371	--
110	1702773	1702773	1702773	1702773	1702773	1702773
111	1704885	1704885	1704885	1704885	1704885	1704885
112 (M3369/M4069 only)	1704830	1704830	1704830	1704830	1704830	1704830
113	1701505	1701505	1701505	1701505	1701505	1701505

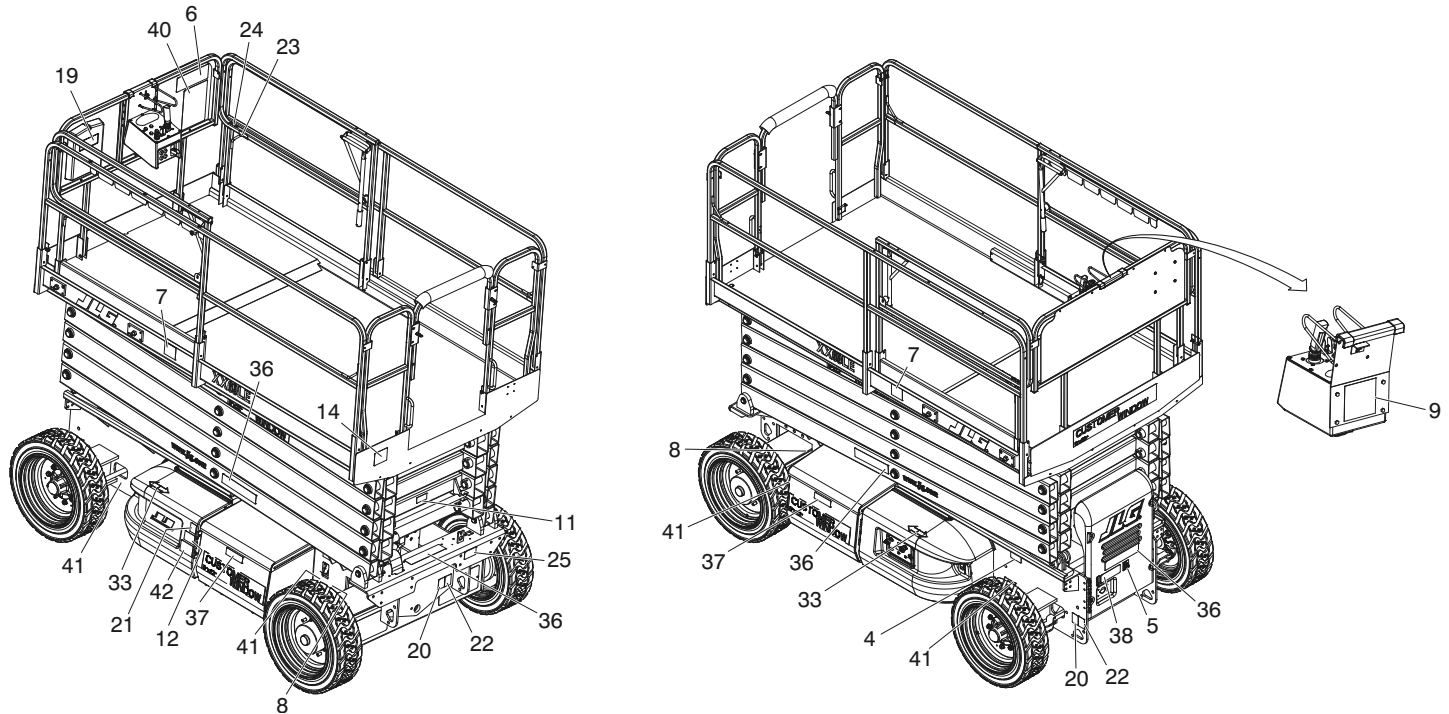

Figure 3-6. Decal Installation (CE/AUS)

SECTION 3 - MACHINE CONTROLS AND INDICATORS

Table 3-3. Decal Location Legend (CE/AUS)

Item #	CE/AUS 0275084_2 3369LE/4069LE	CE/AUS 0275085_2 M3369/M4069
1-3	--	--
4	1700584	1700584
5	1701644	1701644
6	1706338	1706338
7	--	1705084
8	1702155	1702155
9	1702631	1702631
10	--	--
11	1704211	1704211
12	1704412	1704412
13-17	--	--
18	2901912	2901912
19	1701509	1701509
20	1703811	1703811
21	1703812	1703812
22	1703814	1703814
23	1704277	1704277

SECTION 3 - MACHINE CONTROLS AND INDICATORS

Table 3-3. Decal Location Legend (CE/AUS)

Item #	CE/AUS 0275084_2 3369LE/4069LE	CE/AUS 0275085_2 M3369/M4069
24	1703819	1703819
25	1703822	1703822
26 - 32	--	--
33	1703687	1703687
34 - 35	--	--
36	1706338	1706338
37	1705670	1705670
38	1706492	1706492
39	--	--
40	1704530 (3369LE & M3369) 1706491 (3369LE only)	1704580
41	1703490 (3369LE & M3369)	1704953 (4069LE & M4069)
42	1704174	1704174

SECTION 3 - MACHINE CONTROLS AND INDICATORS



NOTES:

<hr/> <hr/> <hr/> <hr/> <hr/> <hr/> <hr/> <hr/> <hr/> <hr/> <hr/> <hr/> <hr/> <hr/> <hr/> <hr/> <hr/> <hr/> <hr/> <hr/> <hr/> <hr/> <hr/>	<hr/> <hr/> <hr/> <hr/> <hr/> <hr/> <hr/> <hr/> <hr/> <hr/> <hr/> <hr/> <hr/> <hr/> <hr/> <hr/> <hr/> <hr/> <hr/> <hr/> <hr/> <hr/> <hr/> <hr/>
---	---

SECTION 4. MACHINE OPERATION

4.1 DESCRIPTION

This machine is a self-propelled hydraulic lift equipped with a work platform on an elevating scissor mechanism. Vibrations emitted by these machines are not hazardous to an operator in the work platform. The equivalent continuous A-Weighted sound pressure level at the work platform is less than 70 dB(A).

The primary operator control station is in the platform. From this control station, the operator can drive and steer the machine in both forward and reverse directions. The machine has a Ground Control Station which will override the Platform Control Station. Ground Controls operate lift and lower and are to be used in an emergency to lower the platform to the ground should the operator in the platform be unable to do so. Ground Control is also to be used in Pre-Start Inspection.

4.2 POWER SELECT

Platform/Ground Select

The Platform/Ground Select switch directs power to the Ground or Platform controls as selected. For power, the POWER/EMERGENCY STOP switch must also be pulled out (on).

4.3 RAISING AND LOWERING

Raising & Lowering

To raise or lower the platform, either use Lift or Lower function and hold switch until desired elevation is reached.



DO NOT LOWER WITHOUT COMPLETELY RETRACTING PLATFORM EXTENSION.

SECTION 4 - MACHINE OPERATION

4.4 LEVELING JACKS

Once the leveling jacks leave the stowed position (fully retracted) but are not fully extended, the lift and drive functions are cut out.

After all 4 jacks are extended and touch a solid surface only the drive function is cut out. Drive function is restored once the jacks are stowed (fully retracted) again.

4.5 PLATFORM EXTENSION

The machine is equipped with a mechanically extendible deck. To extend the deck, lift handle up on the left and right side of the platform to release the latch and use the handle to push the extendible deck out. When the deck reaches the end of its travel, push handle down to latch, this will lock and hold the deck in place. To retract the deck, reverse operation.

4.6 PLATFORM HANDRAILS FOLD DOWN PROCEDURE (IF EQUIPPED)

1. Remove the two pins from platform extension gate and fold gate to the left side handrail.
2. Remove the pin from extension left side handrail, lift up and fold down handrail onto platform deck.
3. Remove the pin from extension right side handrail, lift up and fold down onto platform deck.
4. Remove the two pins from rear handrail, lift up and fold gate down onto platform deck.
5. Lift up left handrail, fold handrail down onto platform deck.
6. Lift up right handrail, fold handrail down onto platform deck.

4.7 STEERING

Position thumb switch on drive/lift/steer controller to right for steering right, or to left for steering left.

WARNING

TO AVOID LOSS OF TRAVEL CONTROL OR UPSET ON GRADES AND SIDE SLOPES, DO NOT DRIVE MACHINE ON GRADES OR SIDE SLOPES EXCEEDING THOSE SPECIFIED ON WARNING PLACARD AT PLATFORM.

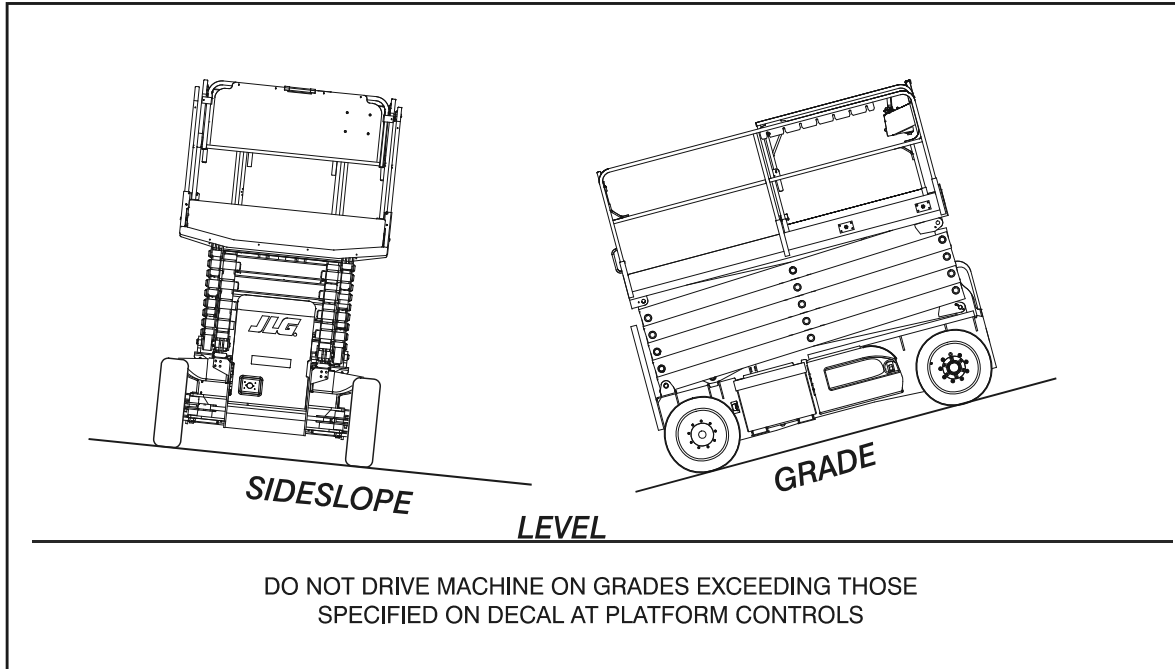

Figure 4-1. Grade and Sideslope

Traveling Forward and Reverse

1. At platform controls, pull out emergency stop switch and select the drive switch.
2. Position drive controller to forward or reverse as desired.

⚠ WARNING

DIRECTION OF DRIVE AND STEER MOVEMENT MAY BE OPPOSITE FROM NORMAL OPERATION. BEFORE DRIVING, LOCATE THE BLACK/WHITE ORIENTATION ARROWS ON BOTH THE CHASSIS AND THE PLATFORM CONTROLS. MOVE THE DRIVE CONTROLS IN A DIRECTION MATCHING THE ORIENTATION ARROWS.

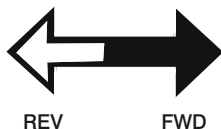

⚠ WARNING

IF TILT ALARM IS ON WHEN PLATFORM IS RAISED, STOP DRIVING AND LOWER PLATFORM COMPLETELY, THEN REPOSITION MACHINE SO THAT IT IS LEVEL BEFORE RAISING PLATFORM.

4.8 SHUT DOWN AND PARK

NOTE: When parking overnight, batteries should be charged properly to ensure readiness for next workday.

To shut down and park the machine, the procedures are as follows:

1. Drive machine to a reasonably well protected area.
2. Ensure platform is fully lowered.
3. Push in the Emergency Stop at platform controls.
4. Push in the Emergency Stop at ground controls. Position platform/ground select switch to center off.
5. If necessary, cover Platform Controls to protect instruction placards, warning decals and operating controls from hostile environment.
6. Chock at least two wheels when parking machine for an extended period of time.

4.9 SAFETY PROP



SAFETY PROP MUST BE USED WHEN MAINTENANCE REQUIRES SIZOR ARMS TO BE RAISED.

1. To engage safety prop, raise platform, pull ring to release safety prop, then rotate prop clockwise until it hangs vertically. Lower the platform until the safety prop rests between the two extended cross-shafts.
2. To store safety prop, reverse operation of step 1.

4.10 BATTERY CHARGING PROCEDURE

The battery charger receptacle is located at the front of the machine. The receptacle is located in the molded front panel.

1. Connect the charger receptacle to a 115 volt (220 volt) power outlet with a 15 amp minimum capacity.
2. The batteries are charged fully when the 100% LED is lit. At this time, the charger will shut off automatically.

NOTE: *Discharged batteries will take approximately 23 hours to charge.*

4.11 TIE DOWN/LIFTING

Tie Down

1. Place platform in stowed position and retract deck extension.
2. Remove all loose items from machine.
3. Secure the chassis using straps or chains of adequate strength.

Lifting

NOTE: *See manufacturer's nameplate for gross weight of machine as originally manufactured.*

1. Place platform in stowed position and retract deck extension.
2. Remove all loose items from machine.
3. Properly adjust rigging to prevent damage to machine and so machine remains level.

NOTICE

DO NOT ATTEMPT TO LIFT MACHINE WITH A FORK TRUCK. FORK POCKETS LOCATED UNDER BATTERY PACKS ARE PROVIDED FOR LIFTING BATTERIES ONLY.

SECTION 4 - MACHINE OPERATION

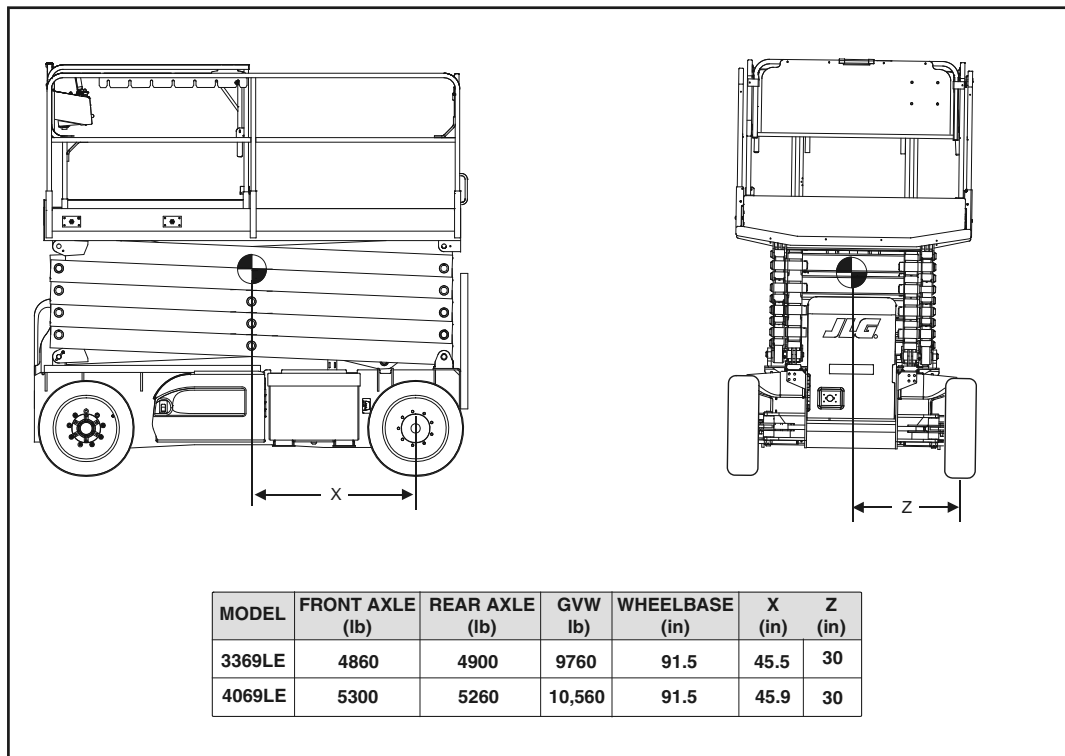

Figure 4-2. Lifting & Tie Down Chart - Sheet 1 of 2

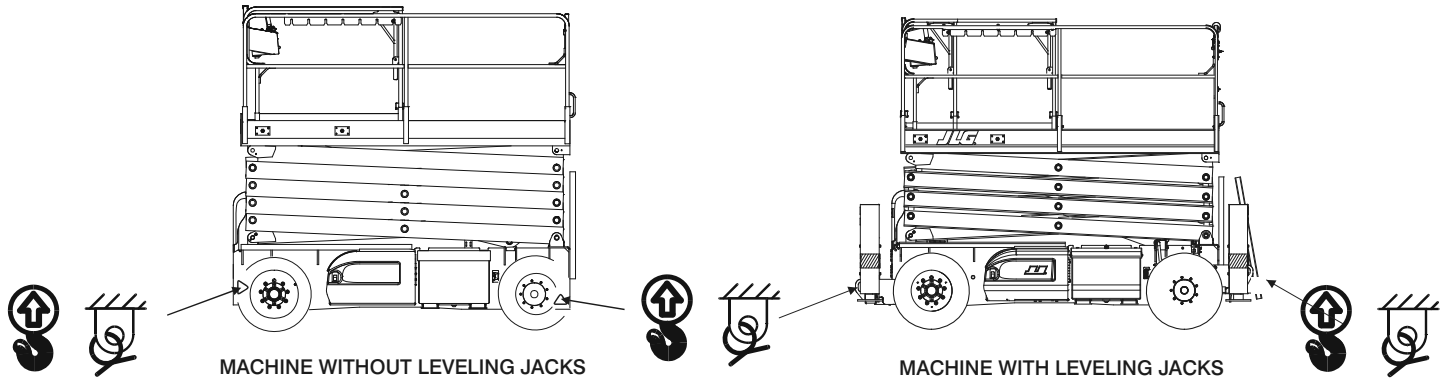

Figure 4-3. Lifting & Tie Down Chart - Sheet 2 of 2

SECTION 4 - MACHINE OPERATION

 **NOTES:**

<hr/> <hr/> <hr/> <hr/> <hr/> <hr/> <hr/> <hr/> <hr/> <hr/> <hr/> <hr/> <hr/> <hr/> <hr/> <hr/> <hr/> <hr/> <hr/> <hr/> <hr/> <hr/> <hr/>	<hr/> <hr/> <hr/> <hr/> <hr/> <hr/> <hr/> <hr/> <hr/> <hr/> <hr/> <hr/> <hr/> <hr/> <hr/> <hr/> <hr/> <hr/> <hr/> <hr/> <hr/> <hr/> <hr/> <hr/>
---	---

SECTION 5. EMERGENCY PROCEDURES

5.1 GENERAL

This section explains the steps to be taken in case of an emergency situation while operating.

5.2 INCIDENT NOTIFICATION

JLG Industries, Inc. must be notified immediately of any incident involving a JLG product. Even if no injury or property damage is evident, the factory should be contacted by telephone and provided with all necessary details.

JLG Phone: 717-485-5161

Failure to notify the manufacturer of an incident involving a JLG Industries product within 48 hours of such an occurrence may void any warranty consideration on that particular machine.

NOTICE

FOLLOWING ANY ACCIDENT, THOROUGHLY INSPECT THE MACHINE AND TEST ALL FUNCTIONS FIRST FROM THE GROUND CONTROLS, THEN FROM THE PLATFORM CONTROLS.

5.3 EMERGENCY TOWING PROCEDURES

Towing this machine is prohibited. However, provisions for moving the machine have been incorporated. The following procedures are to be used **ONLY** for emergency.

1. Chock wheels securely.
2. Engage the brake release on both drive hubs by loosening the bolts, completely reversing hub caps, and retightening the bolts.
3. Connect towing equipment and remove chocks.

After towing machine, complete the following procedure:

1. Position machine on a firm level surface.
2. Chock wheels securely.
3. Disengage the brake release on both drive hubs by loosening the bolts, completely reversing hub caps, and retightening the bolts.
4. Remove chocks.

5.4 MANUAL DESCENT SYSTEM

The manual descent system is used, in the event of total power failure, to lower the platform using gravity. Pull the handle located at the rear of the machine just behind the ladder.

CAUTION

MANUAL DESCENT ON THE 4069LE DOES NOT COMPLETELY LOWER THE PLATFORM. TO LOWER COMPLETELY, USE THE LOWER FUNCTION AT THE GROUND CONTROL. THE PLATFORM WILL LOWER THE LAST SEVERAL INCHES (CM) AT GRAVITY SPEED. KEEP CLEAR OF DESCENDING PLATFORM.

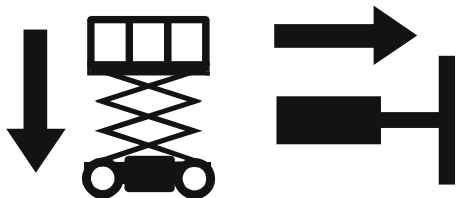

5.5 EMERGENCY OPERATION

Operator Unable to Control Machine

NOTE: *If the platform operator is pinned, trapped or unable to operate or control machine:*

1. Other personnel should operate the machine from ground controls only as required.
2. Other qualified personnel on the platform may use the platform controls. **DO NOT CONTINUE OPERATION IF CONTROLS DO NOT FUNCTION PROPERLY.**
3. Cranes, forklift trucks or other equipment which may be available are to be used to remove platform occupants and stabilize motion of the machine.

Platform Caught Overhead

If the platform or boom becomes jammed or snagged in overhead structures or equipment, rescue platform occupants prior to freeing the machine.

SECTION 6. GENERAL SPECIFICATIONS AND OPERATOR MAINTENANCE

6.1 INTRODUCTION

This section of the manual provides additional necessary information to the operator for proper operation and maintenance of this machine.

The maintenance portion of this section is intended as information to assist the machine operator to perform daily maintenance tasks only, and does not replace the more thorough Preventive Maintenance and Inspection Schedule included in the Service and Maintenance Manual.

Other Publications Available Specific to this Machine:

Service and Maintenance Manual (Domestic) ..	3121122
Illustrated Parts Manual (Domestic).....	3121123
Service and Maintenance Manual (CE	3121824
Illustrated Parts Manual (CE)	3121825

6.2 SUPPLEMENTAL INFORMATION

The following information is provided in accordance with the requirements of the European Machinery Directive 2006/42/EC and is only applicable to CE machines.

For electric powered machines, the equivalent continuous A-Weighted sound pressure level at the work platform is less than 70dB(A).

For combustion engine powered machines, guaranteed Sound Power Level (LWA) per European Directive 2000/ 14/EC (Noise Emission in the Environment by Equipment for Use Outdoors) based on test methods in accordance with Annex III, Part B, Method 1 and 0 of the directive, is 109 dB.

The vibration total value to which the hand-arm system is subjected does not exceed 2,5 m/s². The highest root mean square value of weighted acceleration to which the whole body is subjected does not exceed 0,5 m/s².

SECTION 6 - GENERAL SPECIFICATIONS AND OPERATOR MAINTENANCE

6.3 OPERATING SPECIFICATIONS

Table 6-1. Operating Specifications

Description	3369LE/M3369			4069LE/M4069		
	ANSI	CE/AUS	CSA	ANSI	CE/AUS	CSA
Max. Number of Persons	2			2		
Max. Workload (Capacity)	ANSI/CSA/Brazil:	1000 lbs (454kg)		ANSI/CSA/Brazil:	800 lbs (363kg)	
Extension Only:	CE/AUS:	1000 lbs (450kg)		CE/AUS:	800 lbs (360kg)	
	ANSI/CSA/Brazil:	250 lbs (113kg)		ANSI/CSA/Brazil:	250 lbs (113kg)	
	CE/AUS:	250 lbs (120kg)		CE/AUS:	250 lbs (120kg)	
Max. Platform Height	33 ft (10.06m)			40 ft (12.2 m)		
Max. Gradeability	35%			35%		
Max. Slope (Left - Right)	5° Up to 25 ft (7.6 m) 4° Up to 30 ft (9.1 m) 3° Up to 33 ft (10 m)		3° Up to 33 ft (10 m)	5° Up to 30 ft (9.1 m) 4° Up to 36 ft (11 m) 3° Up to 40 ft (12.2 m)		3° Up to 40 ft (12.2 m)
Max. Slope (Left - Right) (optional for CE machines with 37 mph (16.7 m/s) wind- speed rating only)	NA	4° Up to 25 ft (7.6 m) 2° Up to 33 ft (10 m)	NA	NA		
Max. Slope (Front - Back)	5° Up to 33 ft (10 m)		3° Up to 33 ft (10 m)	5° Up to 40 ft (12.2 m)		3° Up to 40 ft (12.2 m)

SECTION 6 - GENERAL SPECIFICATIONS AND OPERATOR MAINTENANCE

Table 6-1. Operating Specifications

Description	3369LE/M3369			4069LE/M4069		
	ANSI	CE	AUS	ANSI	CE	AUS
Max. Slope (Front - Back) (optional for CE machines with 37 mph (16.7 m/s) wind- speed rating only)	NA	5° Up to 25 ft (7.6 m) 4° Up to 33 ft (10 m)	NA	NA		
Max. Tire Load	3200 lbs (1452 kg)			3700 lbs (1680 kg)		
Max. Ground Bearing Pressure	57 psi (4 kg/cm ²)			61 psi (4.3 kg/cm ²)		
Max. Allowable Wind Speed (Standard rating)	28 mph (12.5 m/s)			28 mph (12.5 m/s)		
Maximum Horizontal Manual Side Force	667 N (150 lb force))	400 N (90 lb force)		534 N (120 lb force)	400N (90 lb force)	
Max. Allowable Wind Speed (16.7 m/s machines only) (Optional rating for CE Speci- fication only)	NA	16.7m/s (37 mph)	NA	NA		
Turning Radius: Inside Outside	7.5 ft (2.3 m) 16 ft (4.9 m)			7.5 ft (2.3 m) 16 ft (4.9 m)		

SECTION 6 - GENERAL SPECIFICATIONS AND OPERATOR MAINTENANCE

Table 6-1. Operating Specifications

Description	3369LE/M3369			4069LE/M4069		
	ANSI	CE	AUS	ANSI	CE	AUS
Wheelbase	91.5 in (2.3m)			91.5 in (2.3 m)		
Gross Machine Weight (Approximate)	9,760 lbs (4,427 kg)	10,060 lbs (4563 kg)		10,560 lbs (4,790 kg)	11,500 lbs (5216.3)	
Maximum Drive Speed	3 mph (4.8 kmh)			3 mph (4.8 kmh)		
Drive Speed - (reduced)	16 - 24 sec/50 ft (15 m)			16 - 24 sec/50 ft (15 m)		
Drive Speed - (high)	10.6 - 12 sec/50 ft (15 m)			10.6 - 12 sec/50 ft (15 m)		
Drive Speed - (creep) (AUS Full drive height model)	NA			NA	142 - 146 sec/25 ft (7.6 m)	
Platform Lift Up Speed (platform empty)	36 - 40 sec			52 - 60 sec		
Platform Lowering Speed (platform empty)	43 - 48 sec			49 - 51 sec		
Max Operating Hydraulic Pressure	3000 psi (207 bar)			3000 psi (207 bar)		
Electrical System Voltage	48 volt			48 volt		
Ground Clearance	8 in (20 cm)			8 in (20 cm)		

SECTION 6 - GENERAL SPECIFICATIONS AND OPERATOR MAINTENANCE

Dimensional Data

Table 6-2. Dimensional Data

	3369LE/M3369	4069LE/M4069
Transport Height (rails down)	76.5 in (1.9 m)	79 in (2 m)
Machine Length	121 in (3.1 m)	
Machine Width	69 in (1.75 m)	

Capacities

Table 6-3. Capacities

Fuel Tank - (M Models only)	Approx. 0.9 gal (3.3 l)
Hydraulic Tank	8.25 gal (31.2 l)
Hydraulic System	8.5 gal (32.1 l)
Generator Crankcase	1.2 qts (1.1 l)

SECTION 6 - GENERAL SPECIFICATIONS AND OPERATOR MAINTENANCE

Tires

Table 6-4. Tire Specifications

Size	240/55 D17.5 R4 Tread (Fill tire with high durometer polyurethane at 90 psi)	IN240/55-17.5 FF	27.2/10.5-15 FF Turf	IN240/55-17.5 Non Marking
Load Rating	7960 lbs @ 95 psi (3611kg @ 655kPa) 7730 lbs @ 90 psi (3506kg @ 621 kPa)	8550 lbs @ 105 psi (3878kg @ 724kPa) 7960 lbs @ 95 psi (3611kg @ 655kPa) 7730 lbs @ 90 psi (3506kg @ 621 kPa)	4019 lbs @ 42 psi (1823kg @ 290 kPa) 2180 lbs @ 32 psi (989kg @ 221 kPa)	8550 lbs @ 105 psi (3878kg @ 724kPa) 7960 lbs @ 95 psi (3611kg @ 655kPa) 7730 lbs @ 90 psi (3506kg @ 621 kPa)
Ply Rating	12 Ply	10 Ply	6 Ply	10 Ply
Wheel Nut Torque	170 ft lbs (230 Nm)			

Batteries (Electric Machines)

Table 6-5. Battery Specifications

Type	706HD	EVL16A-A (AGM)
Voltage	6	6
Reserve Capacity	810 minutes	841 min.
Amp Hour Rating	@ 20 hour rate - 375	@ 20 hour rate - 390

NOTICE

JLG MACHINES EQUIPPED WITH DELTA Q BATTERY CHARGERS ARE DESIGNED FOR THE BEST PERFORMANCE WITH OEM FACTORY APPROVED BATTERIES.

APPROVED JLG REPLACEMENT BATTERIES ARE AVAILABLE THROUGH JLG' S AFTERMARKET PARTS DISTRIBUTION CENTERS OR JLG' S AFTERMARKET PROGRAMS. FOR ASSISTANCE WITH PROPER BATTERY REPLACEMENT, PLEASE CONTACT YOUR LOCAL JLG SUPPORT OFFICE.

BATTERIES APPROVED BY JLG HAVE BEEN TESTED FOR COMPATIBILITY WITH THE ALGORITHM PROGRAMMING OF THE DELTA Q BATTERY CHARGER TO OPTIMIZE BATTERY LIFE AND MACHINE CYCLE TIMES. THE USE OF NON APPROVED BATTERIES IN YOUR JLG EQUIPMENT MAY RESULT IN PERFORMANCE ISSUES OR BATTERY CHARGER FAULT CODES. JLG ASSUMES NO RESPONSIBILITY FOR SERVICE OR PERFORMANCE ISSUES ARISING FROM THE USE OF NON APPROVED BATTERIES.

Critical Stability Weights

Table 6-6. Critical Stability Weights

COMPONENT	lbs	kg
Platform	780	354
Platform Extension	360	163
Foam Filled Tires	207	94
Batteries (Electric Machines - Each)	111	50.3

SECTION 6 - GENERAL SPECIFICATIONS AND OPERATOR MAINTENANCE

Engine

Table 6-7. Engine Specifications

Type	Air Cooled 4 Cycle Deutz Diesel
Displacement	18.7 in ³ (306cc)
Bore x Stroke	3in x 2.5 in (78mm x 64mm)
Number of cylinders	1
Horsepower	6.6HP/3600 rpm (4.9 kw/3600rpm)
Fuel Type	Diesel

Table 6-8. Engine Battery Specifications

BCI Group Size	51R
Cranking Performance	550 Amps @ 32° F (0° C) 450 Amps @ 0° F (-18° C)
Reserve Capacity	80 minutes @ 80° F(27° C)

SECTION 6 - GENERAL SPECIFICATIONS AND OPERATOR MAINTENANCE

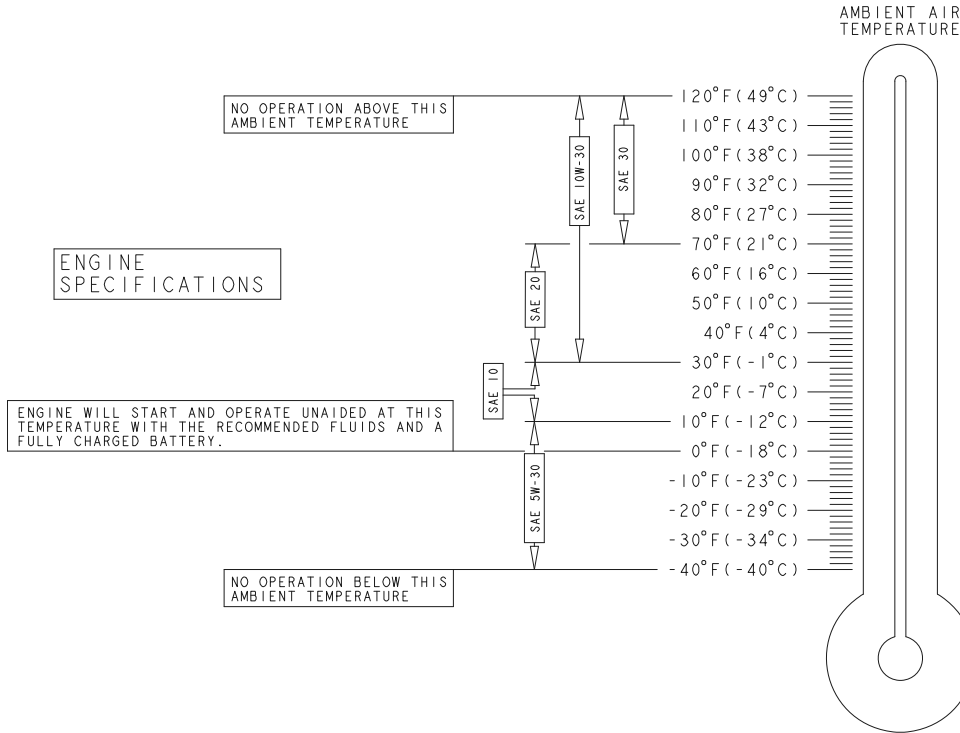

Figure 6-1. Engine Operating Temperature Specifications - (Kubota) Sheet 1 of 2

SECTION 6 - GENERAL SPECIFICATIONS AND OPERATOR MAINTENANCE

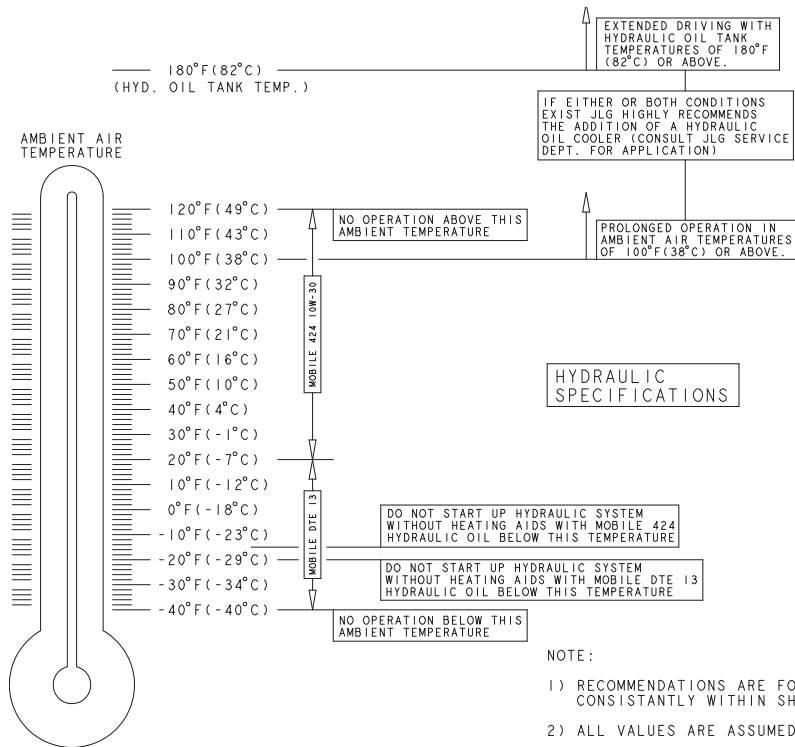

Figure 6-2. Engine Operating Temperature Specifications - (Kubota) Sheet 2 of 2

SECTION 6 - GENERAL SPECIFICATIONS AND OPERATOR MAINTENANCE

Lubrication

Hydraulic Oil

Table 6-9. Hydraulic Oil

HYDRAULIC SYSTEM OPERATING TEMPERATURE RANGE	SAE VISCOSITY GRADE
0° to +23° F (-18° to -5° C)	10W
0° to +210° F (-18° to +100° C)	10W-20, 10W-30
+50° to +210° F (+10° to +100° C)	20W-20

NOTE: Hydraulic oils must have anti-wear qualities at least to API Service Classification GL-3, and sufficient chemical stability for mobile hydraulic system service. JLG Industries recommends Mobilfluid 424 hydraulic oil, which has an SAE viscosity index of 152.

NOTE: When temperatures remain below 20° F (-7° C), JLG Industries recommends the use of Mobil DTE13.

NOTE: Aside from JLG recommendations, it is not advisable to mix oils of different brands or types, as they may not contain the same required additives or be of comparable viscosities. If use of hydraulic oil other than Mobilfluid 424 is desired, contact JLG Industries for proper recommendations.

Lubrication Specifications

Table 6-10. Lubrication Specifications

KEY	SPECIFICATIONS
MPG	Multipurpose Grease having a minimum dripping point of 350° F. Excellent water resistance and adhesive qualities, and being of extreme pressure type. (Timken OK 40 pounds minimum.)
EPGL	Extreme Pressure Gear Lube (oil) meeting API service classification GL-5 or MIL-Spec MIL-L-2105.
EO	Engine (crankcase) Oil. Gas - API SF/SG class, MIL-L-2104. Diesel - API CC/CD class, MIL-L-2104B/MIL-L-2104C.
HO	Hydraulic Oil. API service classification GL-3, e.g. Mobil 424.

6.4 OPERATOR MAINTENANCE

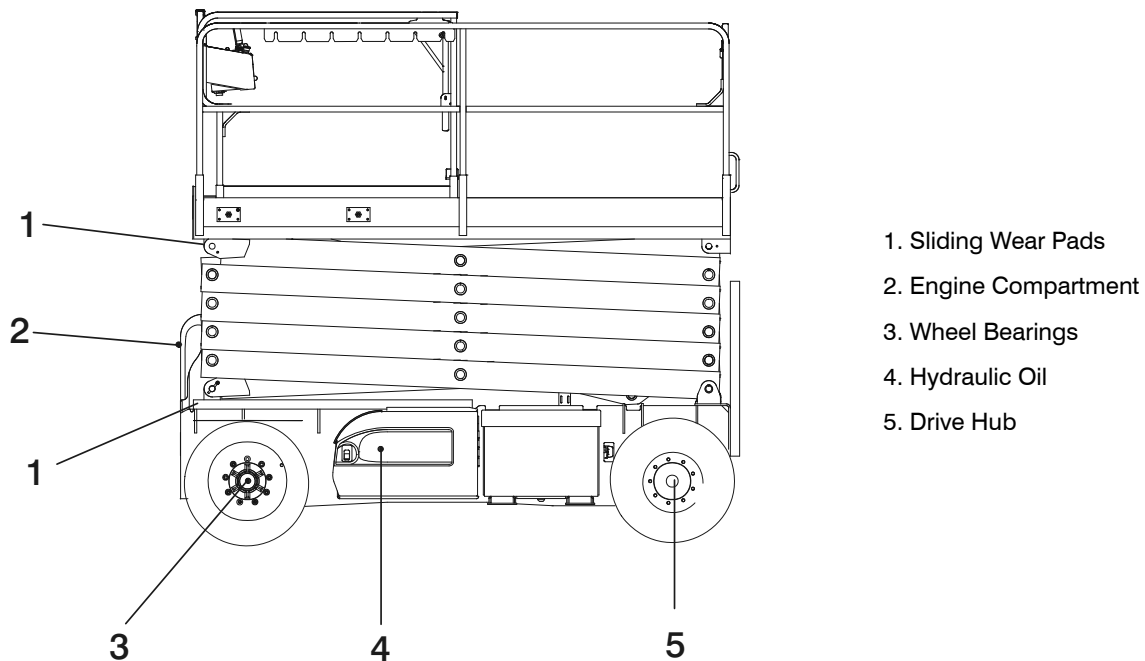

Figure 6-3. Operator Maintenance and Lubrication Diagram

SECTION 6 - GENERAL SPECIFICATIONS AND OPERATOR MAINTENANCE

NOTE: *The following numbers correspond to those in Figure 6-3., Operator Maintenance and Lubrication Diagram.*

1. Sliding Wear Pads
Lube Points - 8 Sliding Wear Pads
Lube - MPG
Interval - Every month or 50 hours.
2. Engine Compartment - The engine compartment is mounted on a sliding tray that pulls out from the front of the machine.
 - a. Engine Oil Check/Fill
Capacity - See Engine Manual
Lube - See Engine Manual
Interval - Check level daily; change per manufacturer's engine manual.
 - b. Air Cleaner
Lube Point - Filter Element
Interval - Check every 3 months or 150 hours; change every 6 months or 300 hours.
 - c. Fuel Filter
Lube Point - Filter Element
Interval - Clean every 3 months or 150 hours; change every 6 months or 300 hours.
3. Wheel Bearings
Lube Points - Front Wheels (2)
Lube - MPG
Interval - Every 2 years or 1200 hours
4. Hydraulic Oil
Lube Point - Fill Level/Drain Plug
Lube - HO
Interval - Check oil every 10 hours of operation; change oil every 2 years or 1200 hours of operation.
5. Drive Hub
Lube Point - Fill Plug
Lube - EPGL
Interval - Every 2 years or 1200 hours

6.5 TIRES AND WHEELS

Tire Damage

For pneumatic tires, JLG Industries, Inc. recommends that when any cut, rip, or tear is discovered that exposes sidewall or tread area cords in the tire, measures must be taken to remove the JLG product from service immediately. Arrangements must be made for replacement of the tire or tire assembly.

For polyurethane foam filled tires, JLG Industries, Inc. recommends that when any of the following are discovered, measures must be taken to remove the JLG product from service immediately and arrangements must be made for replacement of the tire or tire assembly.

- a smooth, even cut through the cord plies which exceeds 3 in. (7.5 cm) in total length
- any tears or rips (ragged edges) in the cord plies which exceeds 1 in. (2.5 cm) in any direction
- any punctures which exceed 1 in. (2.5 cm) in diameter
- any damage to the bead area cords of the tire

If a tire is damaged but is within the above noted criteria, the tire must be inspected on a daily basis to insure the damage has not propagated beyond the allowable criteria.

Tire Replacement

JLG recommends a replacement tire be the same size, ply and brand as originally installed on the machine. Please refer to the JLG Parts Manual for the part number of the approved tires for a particular machine and model. If not using a JLG approved replacement tire, we recommend that replacement tires have the following characteristics:

- Equal or greater ply/load rating and size of original
- Tire tread contact width equal or greater than original
- Wheel diameter, width, and offset dimensions equal to the original.

Unless specifically approved by JLG Industries Inc. do not replace a foam filled tire assembly with a pneumatic tire. When selecting and installing a replacement tire, ensure that all tires are inflated to the pressure recommended by JLG. Due to size variations between tire brands, both tires on the same axle should be the same.

Wheel Replacement

The rims installed on each product model have been designed for stability requirements which consist of track width, tire pressure, and load capacity. Size changes such as rim width, center piece location, larger or smaller diameter, etc., without written factory recommendations, may result in an unsafe condition regarding stability.

Wheel Installation

It is extremely important to apply and maintain proper wheel mounting torque.

⚠ WARNING

WHEEL NUTS MUST BE INSTALLED AND MAINTAINED AT THE PROPER TORQUE TO PREVENT LOOSE WHEELS, BROKEN STUDS, AND POSSIBLE DANGEROUS SEPARATION OF WHEEL FROM THE AXLE. BE SURE TO USE ONLY THE NUTS MATCHED TO THE CONE ANGLE OF THE WHEEL.

Tighten the lug nuts to the proper torque to prevent wheels from coming loose. Use a torque wrench to tighten the fasteners. If you do not have a torque wrench, tighten the fasteners with a lug wrench, then immediately have a service garage or dealer tighten the lug nuts to the proper torque. Over-tightening will result in breaking the studs or permanently deforming the

mounting stud holes in the wheels. The proper procedure for attaching wheels is as follows:

1. Start all nuts by hand to prevent cross threading. DO NOT use a lubricant on threads or nuts.
2. Tighten nuts in the following sequence:

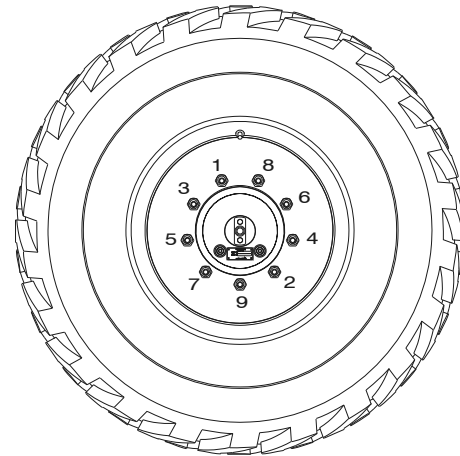

9 LUG PATTERN

3. The tightening of the nuts should be done in stages. Following the recommended sequence, tighten the nuts per wheel torque chart.

SECTION 6 - GENERAL SPECIFICATIONS AND OPERATOR MAINTENANCE

Table 6-11. Wheel Torque Chart

TORQUE SEQUENCE		
1st Stage	2nd Stage	3rd Stage
40-50 ft lbs (60-70 Nm)	90-105 ft lbs (125-150 Nm)	145-170 ft lbs (200-240 Nm)

Wheel nuts should be torqued after first 50 hours of operation and after each wheel removal. Check torque every 3 months or 150 hours of operation.

SECTION 7. INSPECTION AND REPAIR LOG

Table 7-1. Inspection and Repair Log

Date	Comments

SECTION 7 - INSPECTION AND REPAIR LOG

Table 7-1. Inspection and Repair Log

Date	Comments



An Oshkosh Corporation Company

TRANSFER OF OWNERSHIP

To Product Owner:

If you now own but **ARE NOT** the original purchaser of the product covered by this manual, we would like to know who you are. For the purpose of receiving safety-related bulletins, it is very important to keep JLG Industries, Inc. updated with the current ownership of all JLG products. JLG maintains owner information for each JLG product and uses this information in cases where owner notification is necessary.

Please use this form to provide JLG with updated information with regard to the current ownership of JLG products. Please return completed form to the JLG Product Safety & Reliability Department via facsimile or mail to address as specified below.

Thank You,
Product Safety & Reliability Department
JLG Industries, Inc.
13224 Fountainhead Plaza
Hagerstown, MD 21742
USA
Telephone: +1-717-485-6591
Fax: +1-301-745-3713

NOTE: Leased or rented units should not be included on this form.

Mfg. Model: _____

Serial Number: _____

Previous Owner: _____

Address: _____

Country: _____ Telephone: (____) _____

Date of Transfer: _____

Current Owner: _____

Address: _____

Country: _____ Telephone: (____) _____

Who in your organization should we notify?

Name: _____

Title: _____

PROPOSITION 65 WARNING

- **Battery posts, terminals and related accessories contain lead and lead compounds, chemicals known to the State of California to cause cancer and reproductive harm.**
- **Batteries also contain other chemicals known to the State of California to cause cancer.**
- **Wash hands after handling.**



WARNING:



The engine exhaust from this product contains chemicals known to the State of California to cause cancer, birth defects, or other reproductive harm.

1702961



An Oshkosh Corporation Company

Corporate Office
JLG Industries, Inc.
1 JLG Drive
McConnellsburg PA. 17233-9533
USA

(717) 485-5161

(717) 485-6417



3121220

JLG Worldwide Locations

JLG Industries (Australia)
P.O. Box 5119
11 Bolwarra Road
Port Macquarie
N.S.W. 2444
Australia

+61 2 65 811111

+61 2 65 810122

JLG Latino Americana Ltda.
Rua Eng. Carlos Stevenson,
80-Suite 71
13092-310 Campinas-SP
Brazil

+55 19 3295 0407

+55 19 3295 1025

JLG Industries (UK) Ltd
Bentley House
Bentley Avenue
Middleton
Greater Manchester
M24 2GP - England

+44 (0)161 654 1000

+44 (0)161 654 1001

JLG France SAS
Z.I. de Baulieu
47400 Faulliet
France

+33 (0)5 53 88 31 70

+33 (0)5 53 88 31 79

JLG Deutschland GmbH
Max-Planck-Str. 21
D - 27721 Ritterhude - Ihlpohl
Germany

+49 (0)421 69 350 20

+49 (0)421 69 350 45

JLG Equipment Services Ltd.
Rm 1107 Landmark North
39 Lung Sum Avenue
Sheung Shui N. T.
Hong Kong

(852) 2639 5783

(852) 2639 5797

JLG Industries (Italia) s.r.l.
Via Po. 22
20010 Pregnana Milanese - MI
Italy

+39 029 359 5210

+39 029 359 5845

Oshkosh - JLG Singapore T. E. P. Ltd.
29 Tuas Ave 4
Jurong Industrial Estate
639379
Singapore

+65-6591-9030

+65-6591-9031

JLG Polska
Ul. Krolewska
00-060 Warszawa
Poland

+48 (0)914 320 245

+48 (0)914 358 200

JLG Industries (Scotland)
Wright Business Centre
1 Lonmay Road
Queenslie, Glasgow G33 4EL
Scotland

+44 (0)141 781 6700

+44 (0)141 773 1907

Plataformas Elevadoras
JLG Iberica, S.L.
Trapadella, 2
P.I. Castellbisbal Sur
08755 Castellbisbal, Barcelona
Spain

+34 93 772 4700

+34 93 771 1762

JLG Sverige AB
Enkopingsvagen 150
Box 704
SE - 176 27 Jarfalla
Sweden

+46 (0)850 659 500

+46 (0)850 659 534